



Innovation for construction & the environment

Also part of :



Schweizerischer Ingenieur- und Architektenverein
Société suisse des ingénieurs et des architectes
Società svizzera degli ingegneri e degli architetti
Swiss society of engineers and architects

Dr. Dimitrios Terzis

01/10/2024

Today's class

- Structural Health Monitoring (SHM)
- Digital Twins & semantics
- Cyberphysical systems
- Two examples from the EPFL Innovation ecosystem





52 Mio CHF

3 months

Christmas eve

4 winters





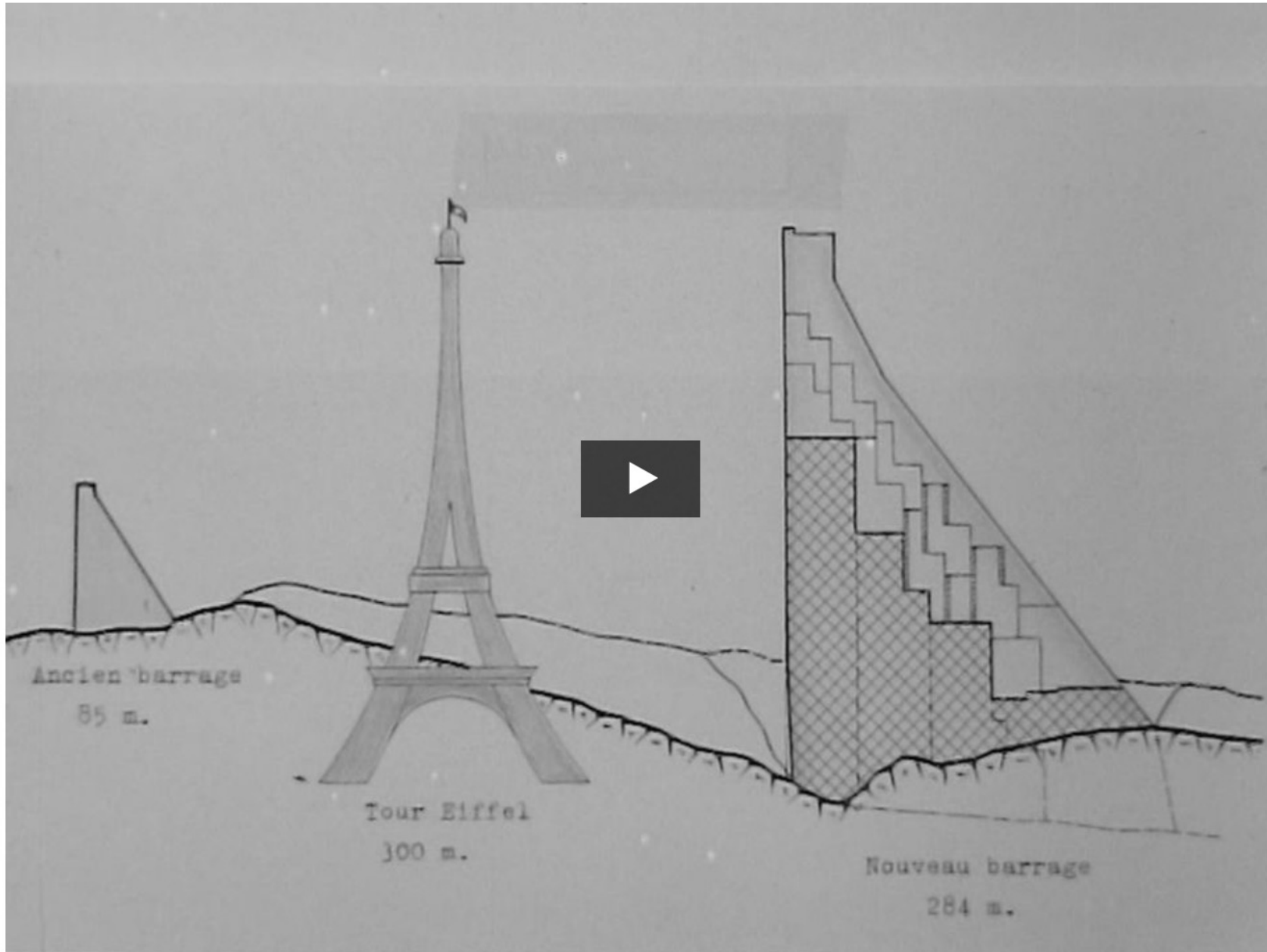

La sécurité du barrage de la Grande Dixence / Le Régional / 5 min. / le 14 octobre 1960

Valais Modifié vendredi à 20:33



Des installations de la Grande Dixence remises à neuf pour 240 millions

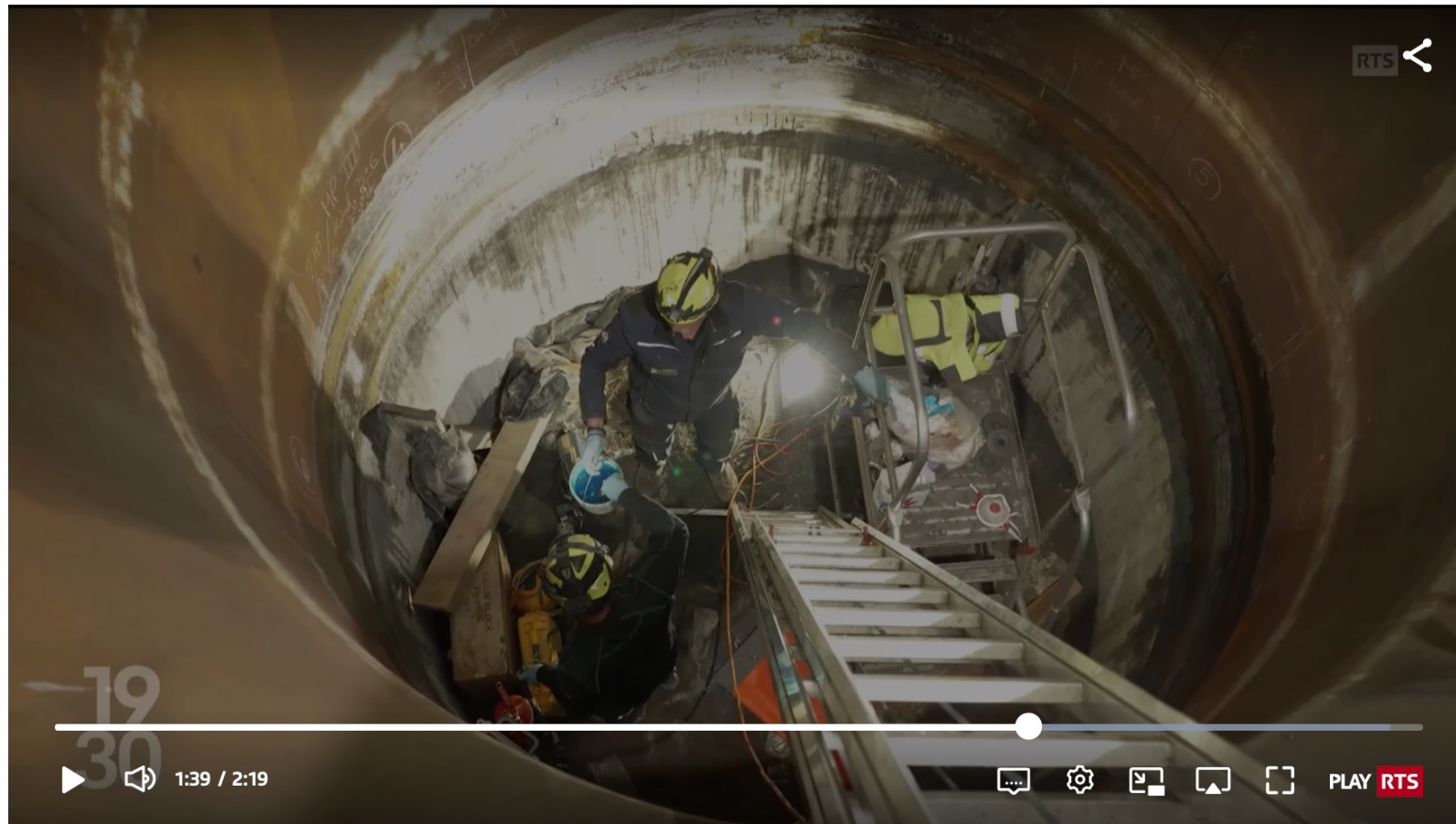

Après six ans de travaux, la rénovation de la Grande Dixence touche à sa fin / 19h30 / 2 min. / vendredi à 19:30

On SHM of Dams

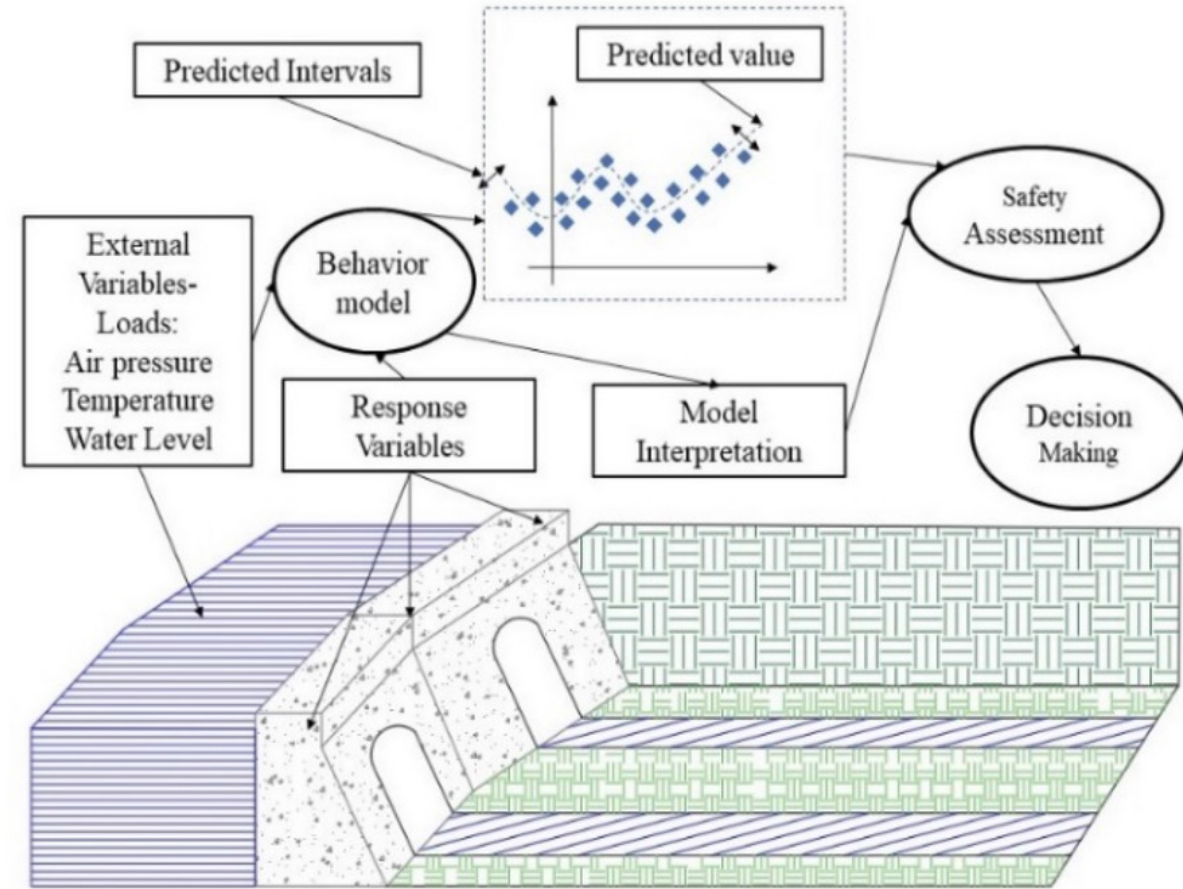

Flah, M., Nunez, I., Ben Chaabene, W. and Nehdi, M.L., 2021. Machine learning algorithms in civil structural health monitoring: A systematic review. *Archives of computational methods in engineering*, 28, pp.2621-2643.



https://www.chemengonline.com/Assets/whitepapers/Oracle_PPM_US_EN_WP_TheImpactofAgeing.pdf

Ageing infrastructure is a headache for many industries. A substantial majority (87%) of executives report that ageing infrastructure has had an impact on their operations in recent years; one in ten say problems related to ageing infrastructure have caused severe problems in their operations that they are still trying to address successfully.

The current infrastructure upgrade spend will rise. Almost 33% of executives say they plan to increase spending on infrastructure in the coming years, while just 8% plan to decrease spending.

Fully 17% of executives say their companies will spend more than 40% of their operating budget on projects involving ageing infrastructure in the coming five years.

On SHM of bridges

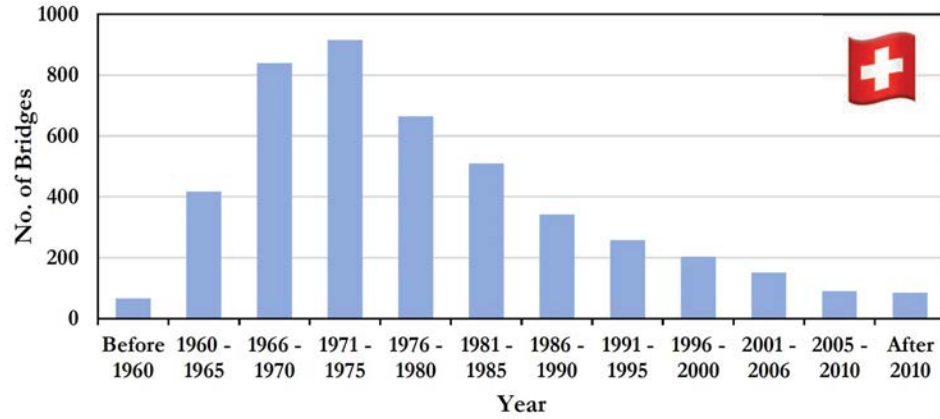

Figure 3: Bridge Construction by Year [Switzerland] ((FEDRO) Office Fédéral des Routes, 2018)

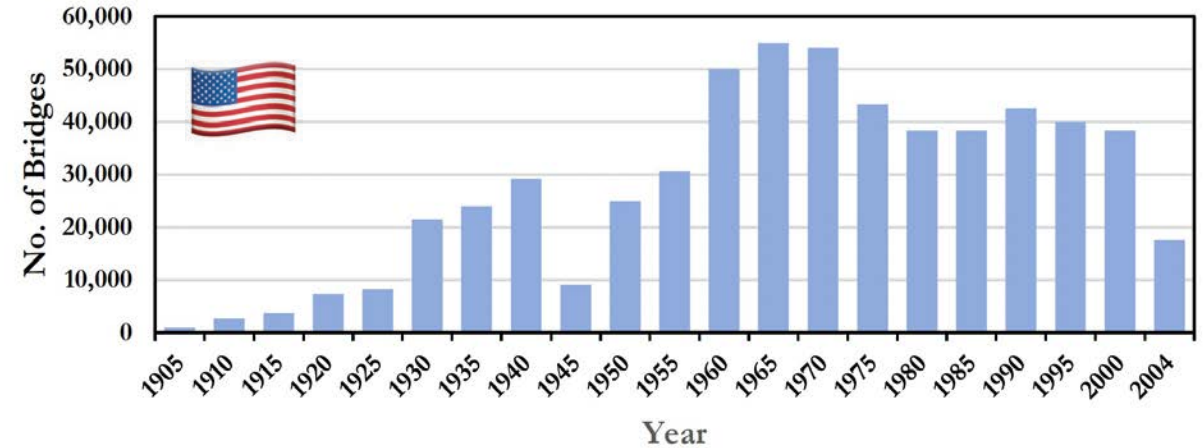

Figure 1: Bridge construction by year [USA] (Choate & Walter, 1981)

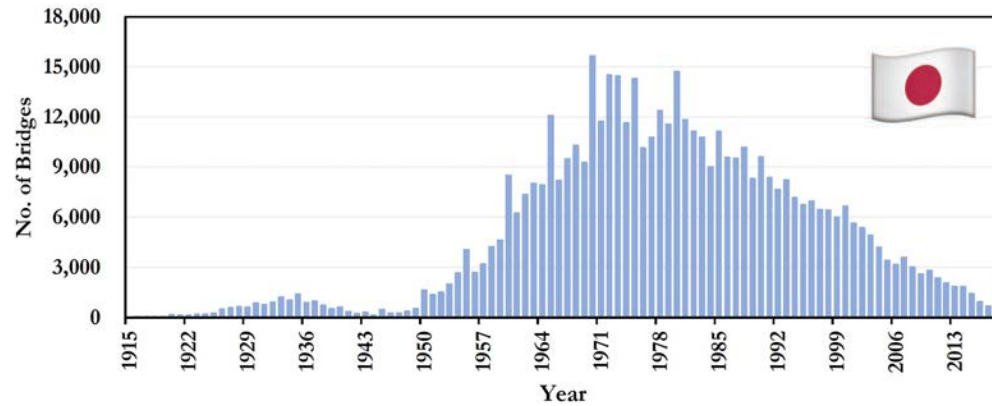

Figure 2: Bridge construction by year [Japan] (MLIT Ministry of Land, 2019)

On SHM of tunnels

Case study: Serre de la Voûte tunnel

Horseshoe shaped tunnel

Crown: small cement bricks

Side walls: rock blocs masonry

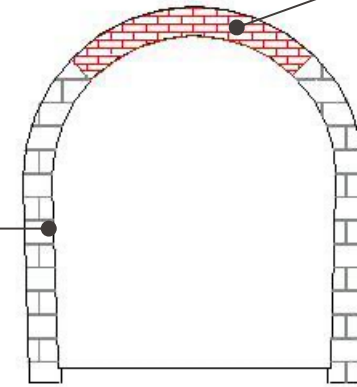

Sclerometer results	Zone (cm from the surface)	Material
No response	0.5 -1.0	Dust, result of several years of operation
9-13	2	Highly weathered material
26-39	2.5 - 3	Sound material

Local hammering for checking the deterioration degree of the rock blocs:

On SHM of tunnels

Case study: Serre de la Voûte tunnel

- The majority of the masonry joints is highly weathered
- Dripping points, mainly located on the tunnel crown
- **Local deformation of the side wall** on a 30 m long zone close to the North portal

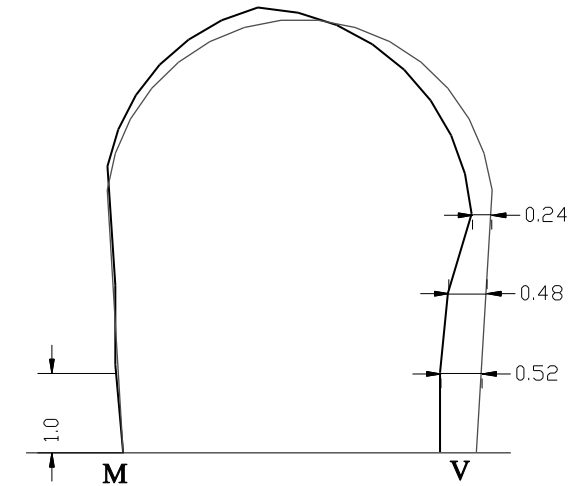
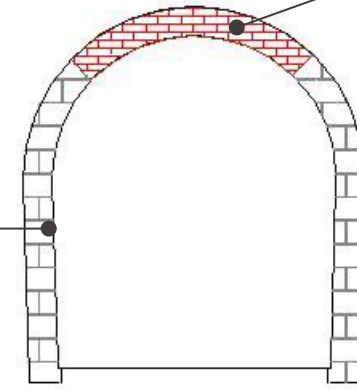

On SHM of metallic structures

■ INNOVATION FOR CONSTRUCTION AND THE ENVIRONMENT





The digital twin

The "Digital twin" programme is one of the major campaigns launched in-house by the Engineering & Projects (I & P) and Innovation Divisions. The aim is to optimise project design, service portfolio content and production functions.

A technological innovation with multiple applications to enter service by 2024

Like the ghost in video games, a digital twin is the virtual reproduction of a system as it really exists and not as it would be in an ideal world. NASA was the first to apply this principle to its industrial requirements for the Apollo mission. The technique is also widely used in the aerospace industry. SNCF Réseau is aiming to have it in service by 2024.

"The (rail) sector has taken inspiration from the aeronautics industry, a precursor in the field, particularly with the digital twins used for reactors to factor in the whole of their lifecycle operating history."

Pierre Cresci, Cabinet Oliver Wyman

On Digital twins

The construction industry is among the least digitized.

McKinsey Global Institute industry digitization index; 2015 or latest available data

Relatively low digitization Relatively high digitization

● Digital leaders within relatively undigitized sectors



¹Based on a set of metrics to assess digitization of assets (8 metrics), usage (11 metrics), and labor (8 metrics).

²Information and communications technology.

Source: AppBrain; Bluewolf; Computer Economics; eMarketer; Gartner; IDC Research; LiveChat; US Bureau of Economic Analysis; US Bureau of Labor Statistics; US Census Bureau; McKinsey Global Institute analysis

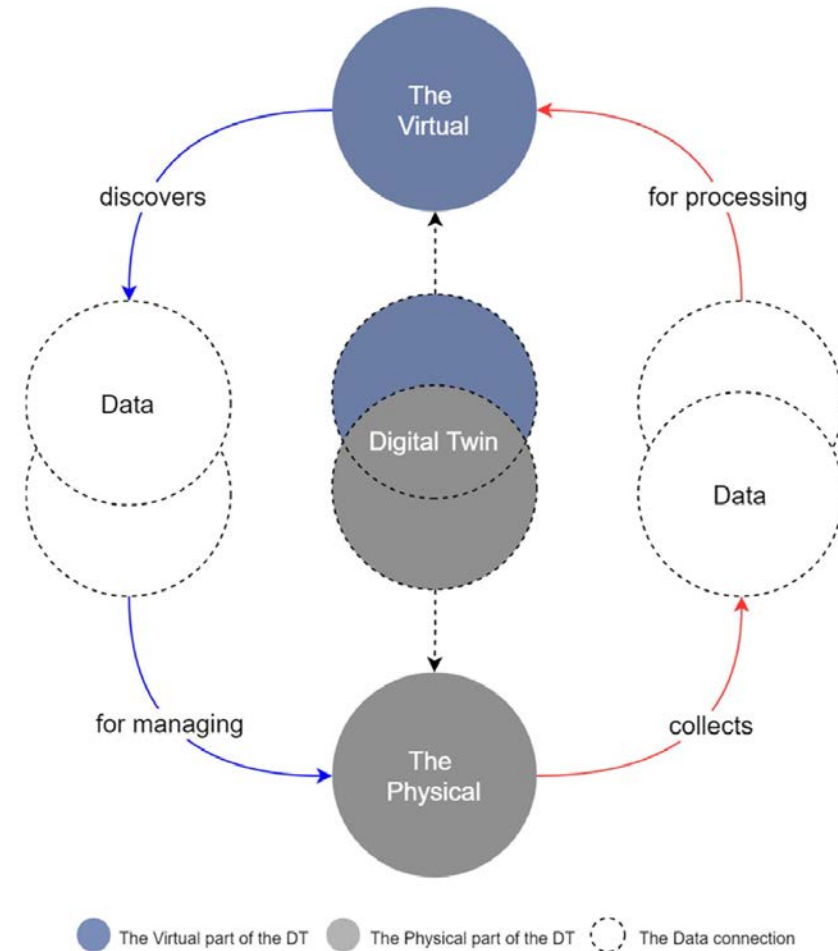

Fig. 1. The Digital Twin paradigm.

Boje, C., Guerriero, A., Kubicki, S. and Rezgui, Y., 2020. Towards a semantic Construction Digital Twin: Directions for future research. *Automation in construction*, 114, p.103179.

On Digital twins

The construction industry is among the least digitized.

McKinsey Global Institute industry digitization index; 2015 or latest available data

Relatively low digitization Relatively high digitization

● Digital leaders within relatively undigitized sectors

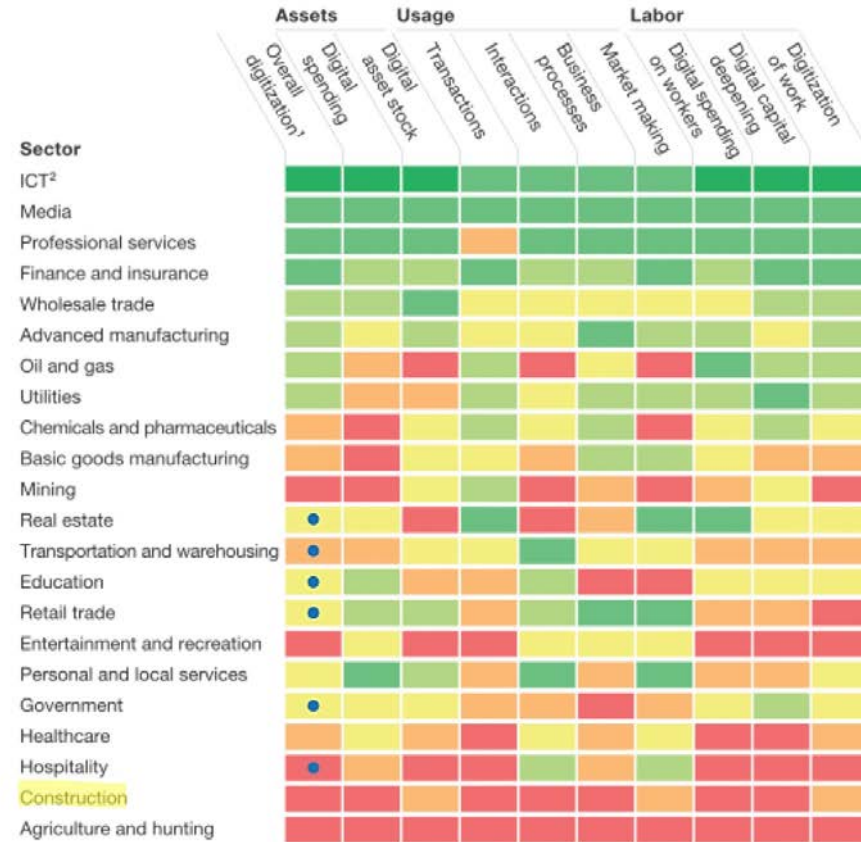

¹Based on a set of metrics to assess digitization of assets (8 metrics), usage (11 metrics), and labor (8 metrics).

²Information and communications technology.

Source: AppBrain; Bluewolf; Computer Economics; eMarketer; Gartner; IDC Research; LiveChat; US Bureau of Economic Analysis; US Bureau of Labor Statistics; US Census Bureau; McKinsey Global Institute analysis

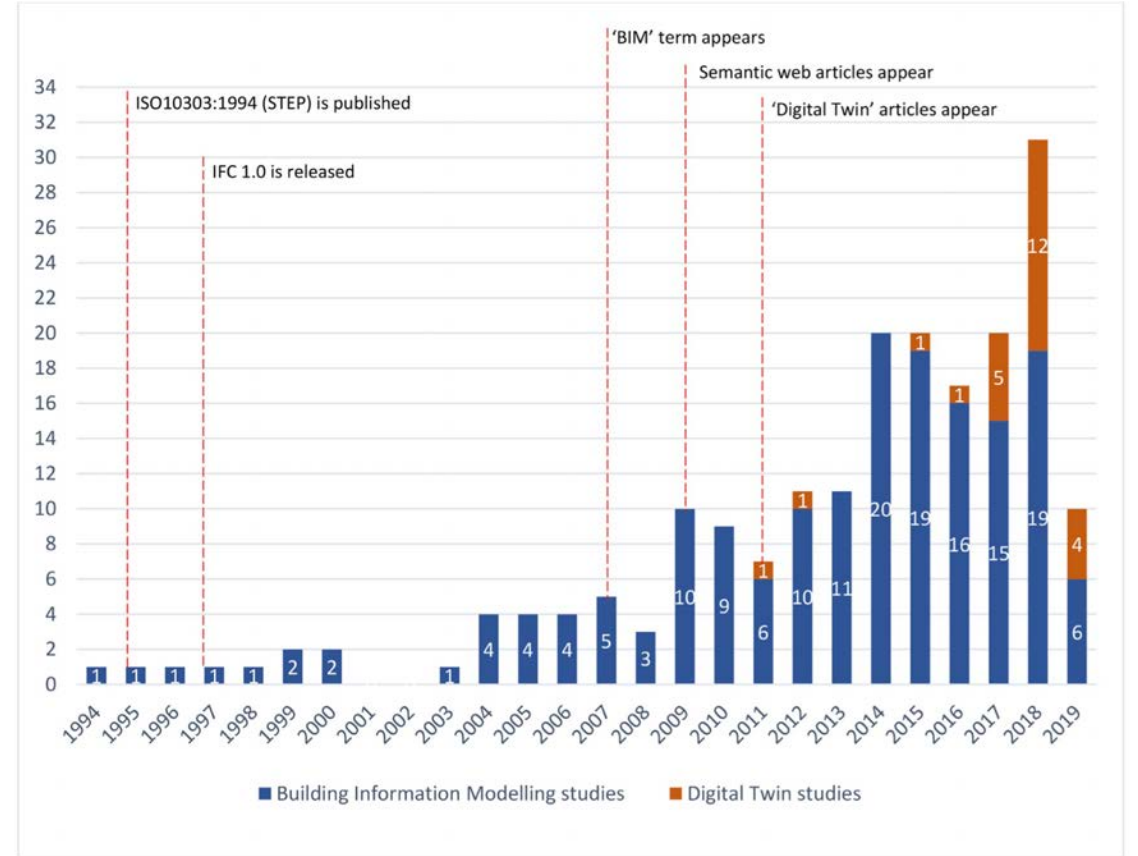
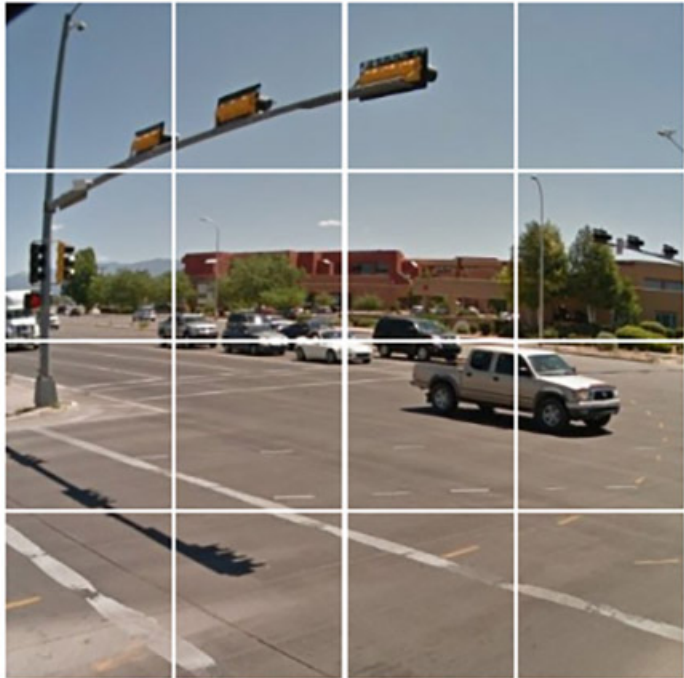

Fig. 3. Distribution of reviewed papers by publication date with important milestones in the construction sector.

Boje, C., Guerriero, A., Kubicki, S. and Rezgui, Y., 2020. Towards a semantic Construction Digital Twin: Directions for future research. *Automation in construction*, 114, p.103179.

A break to understand semantics

Select all squares with **traffic lights**



↻ 🎧 ⓘ

VERIFY

A break to understand semantics

Select all squares with traffic lights

VERIFY

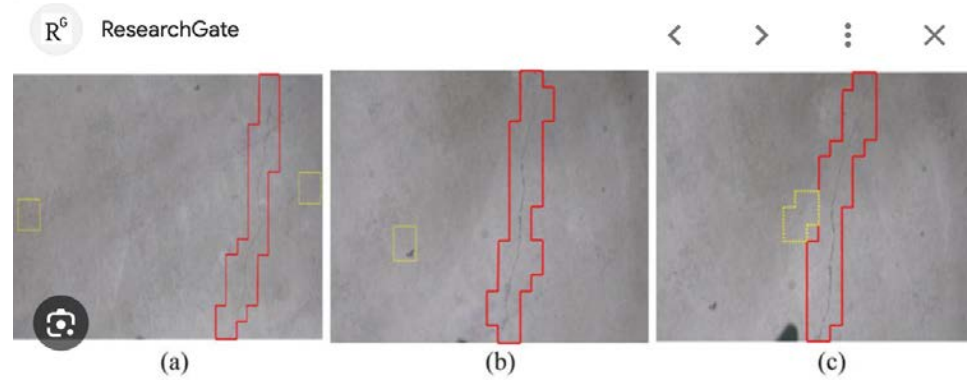

Concrete crack detection results from E2-399. | Download Scientific Diagram

Images may be subject to copyright. [Learn More](#)

Share
 Save

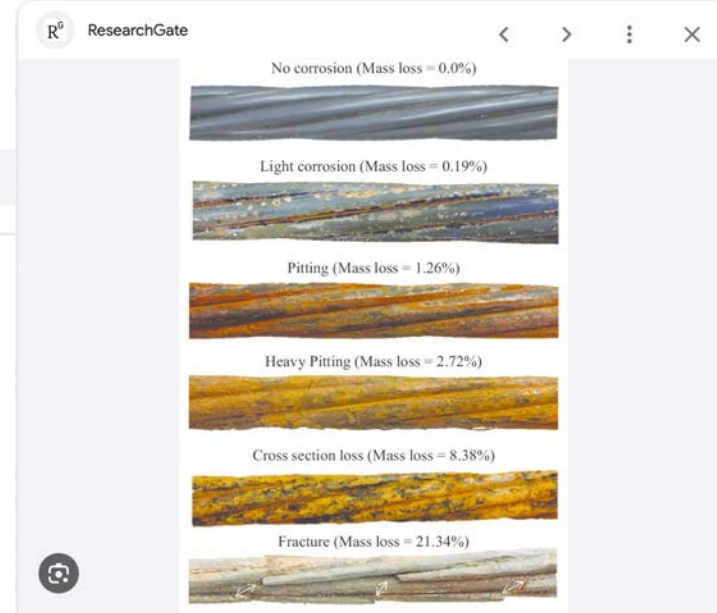

Visual inspection of corrosion progress in a steel strand. | Download Scientific Diagram

Images may be subject to copyright. [Learn More](#)

Share
 Save

[Visit >](#)

On Digital twins & Cyberphysical systems

The construction industry is among the least digitized.

McKinsey Global Institute industry digitization index; 2015 or latest available data

Relatively low digitization Relatively high digitization
● Digital leaders within relatively undigitized sectors



¹Based on a set of metrics to assess digitization of assets (8 metrics), usage (11 metrics), and labor (8 metrics).

²Information and communications technology.

Source: AppBrain; Bluewolf; Computer Economics; eMarketer; Gartner; IDC Research; LiveChat; US Bureau of Economic Analysis; US Bureau of Labor Statistics; US Census Bureau; McKinsey Global Institute analysis

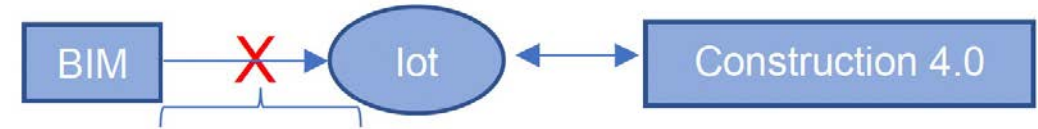

- Lack of sensor networks and control systems
- Incompatible legacy formats and standards

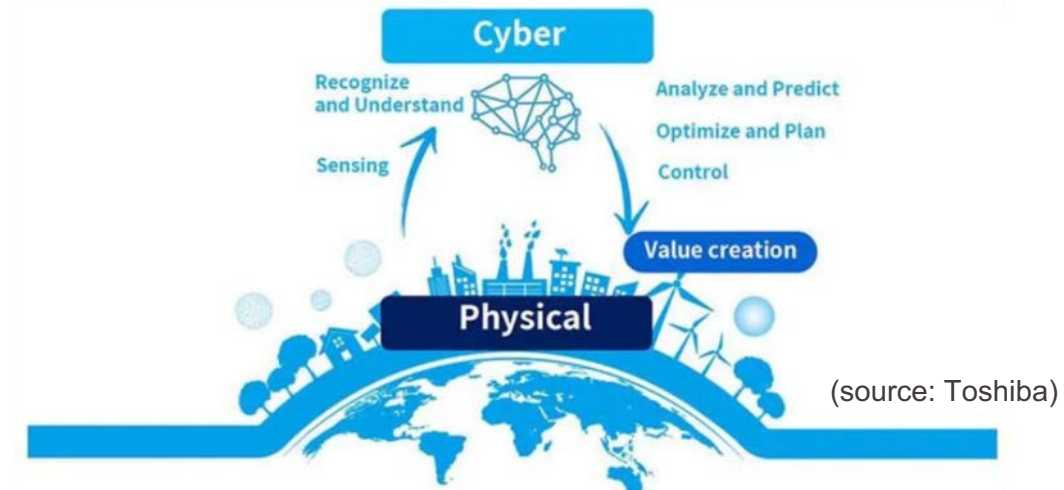
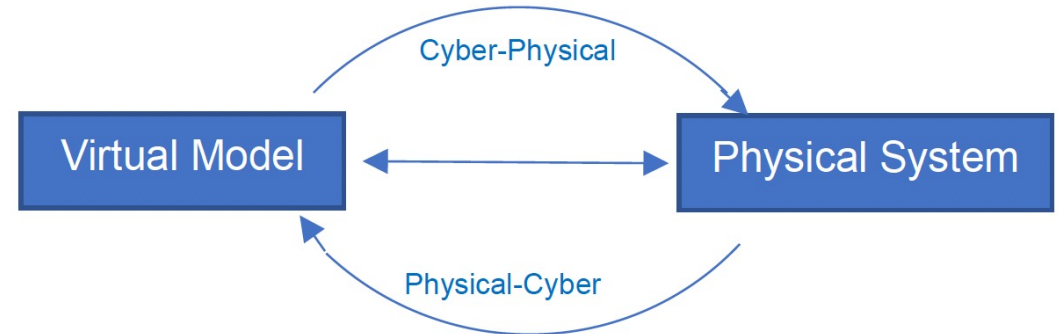

(source: Toshiba)

On Digital twins & Cyberphysical systems

The construction industry is among the least digitized.

McKinsey Global Institute industry digitization index; 2015 or latest available data

Relatively low digitization Relatively high digitization
● Digital leaders within relatively undigitized sectors



¹Based on a set of metrics to assess digitization of assets (8 metrics), usage (11 metrics), and labor (8 metrics).

²Information and communications technology.

Source: AppBrain; Bluewolf; Computer Economics; eMarketer; Gartner; IDC Research; LiveChat; US Bureau of Economic Analysis; US Bureau of Labor Statistics; US Census Bureau; McKinsey Global Institute analysis

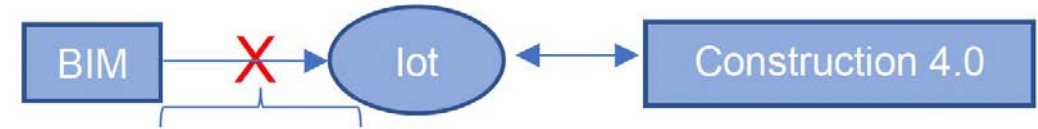

- Lack of sensor networks and control systems
- Incompatible legacy formats and standards

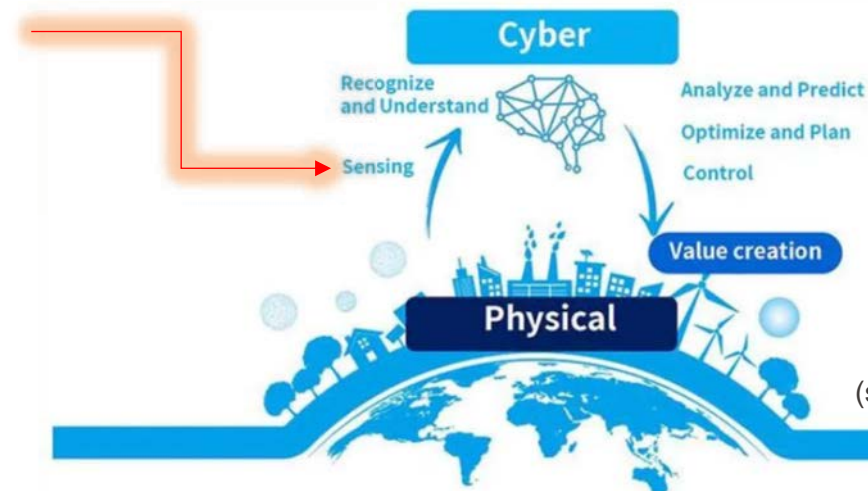
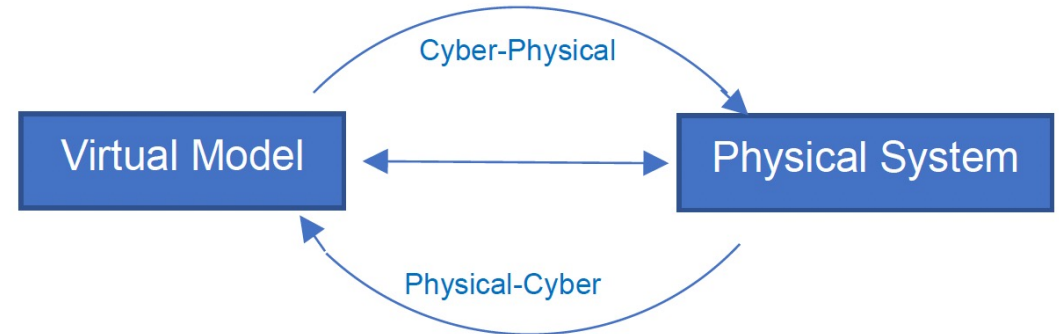

(source: Toshiba)

On Digital twins & Cyberphysical systems

The construction industry is among the least digitized.

McKinsey Global Institute industry digitization index; 2015 or latest available data

Relatively low digitization Relatively high digitization
 ● Digital leaders within relatively undigitized sectors



¹Based on a set of metrics to assess digitization of assets (8 metrics), usage (11 metrics), and labor (8 metrics).

²Information and communications technology.

Source: AppBrain; Bluewolf; Computer Economics; eMarketer; Gartner; IDC Research; LiveChat; US Bureau of Economic Analysis; US Bureau of Labor Statistics; US Census Bureau; McKinsey Global Institute analysis

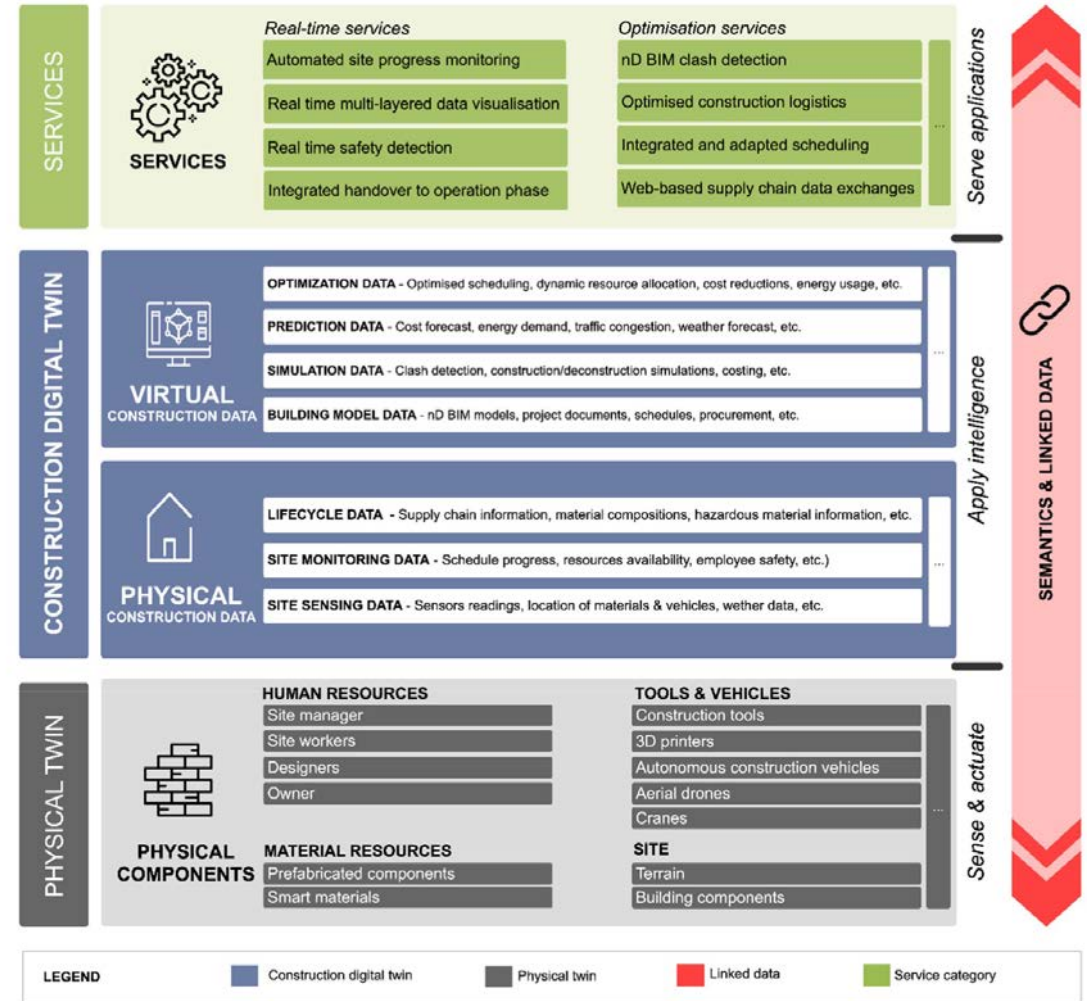

Fig. 5. Construction Digital Twin data usage for facilitating smart construction services (based on Tao et al. [106]).

Boje, C., Guerriero, A., Kubicki, S. and Rezgui, Y., 2020. Towards a semantic Construction Digital Twin: Directions for future research. *Automation in construction*, 114, p.103179.

[Home](#)[Developers](#)[About Us](#)[Contact Us](#)

We help you optimize Hydropower assets

More efficient energy generation and trading thanks to near real-time snow monitoring from space. Committed to Open Source and with a strong partner network, we transparently deliver satellite data power to the Energy industry.

- 3D Space
- Time
- Cost (resources management)
- Environment

Keyword: *Parametric design*



DeFROST

Home Developers About Us Contact Us

Space Data

As climate changes, we help you adapt.

1600GB
SATELLITE DATA PROCESSED DAILY

6M EUR
POTENTIAL EARNINGS, TEST BASIN

30%
REDUCTION SNOWMELT PREDICTION ERROR

15%
BETTER TOTAL INFLOW PREDICTION

Hydropower companies are performing below optimal levels due to errors in discharge prediction models, causing losses in energy planning and trading, exacerbated by climate change. Satellite-based snow data from DeFROST is a product ready to be plugged in to tackle this challenge.

Open Space Data

Our commitment to Open Source algorithms and data makes DeFROST transparent, giving you visibility and full control.

Expertise Network

Thanks to our Open Principles, we are closely connected to the global collaborative network of Space Data expertise and innovation.

Agile Innovation

Working with us means working with an international team of space data innovators. Speed and Agility is part of our DNA.

- 3D Space
 - Time
 - Cost (resources management)
 - Environment
- Keyword: *Parametric design*

Use cases About News Contact us

AI-Powered Solution for Traceable Damage State Estimation of Infrastructure and Buildings

Get in touch → How it works



The image shows a dark blue background with a white drone flying over a stylized landscape. The text 'SWISS INSPECT' is prominently displayed in white and red. Navigation buttons for 'Get in touch' and 'How it works' are visible.



The image features a large bridge over water at sunset. The 'BRIDGOLOGY' logo is overlaid on the right side. Text at the bottom reads 'ADVANCED STRUCTURE ASSESSMENT USING GROUND PENETRATING RADAR'.

■ INNOVATION FOR CONSTRUCTION AND THE ENVIRONMENT

venturelab Home Startups Programs Events News Partnering About

Akselos gets strategic investment from GRO Capital to propel advancements in physics-based digital twins

14.06.2023 10:33, Rita Longobardi

Akselos, the creator of a pioneering engineering simulation technology, announced it has received an investment from GRO to accelerate organizational expansion, global commercial scaling, and product leadership.

Grounded in more than 15 years of advanced academic research at the Massachusetts Institute of Technology ("MIT"), Akselos provides physics-based simulation engineering software, or digital twins, of highly complex mechanical assets. The technology enables customers to reduce risk, increase operational efficiency, and extend the life of their energy infrastructure in operation. The Company is disrupting the industry standard with its solution being 1,000x faster than legacy technology, facilitating real-time condition monitoring and delivering significant customer value.



Akselos' digital twin technology is currently in use by customers across the energy industry, including upstream and downstream, and renewable energy. It is trusted by clients including Shell, Lamprell, and Pan American Energy. Offshore wind is a key vertical, aligning with the company's vision of providing technology that enables the green energy transition in line with IEA's Net Zero 2050 roadmap.



Future and perspectives

Number of structures by type of political authorities

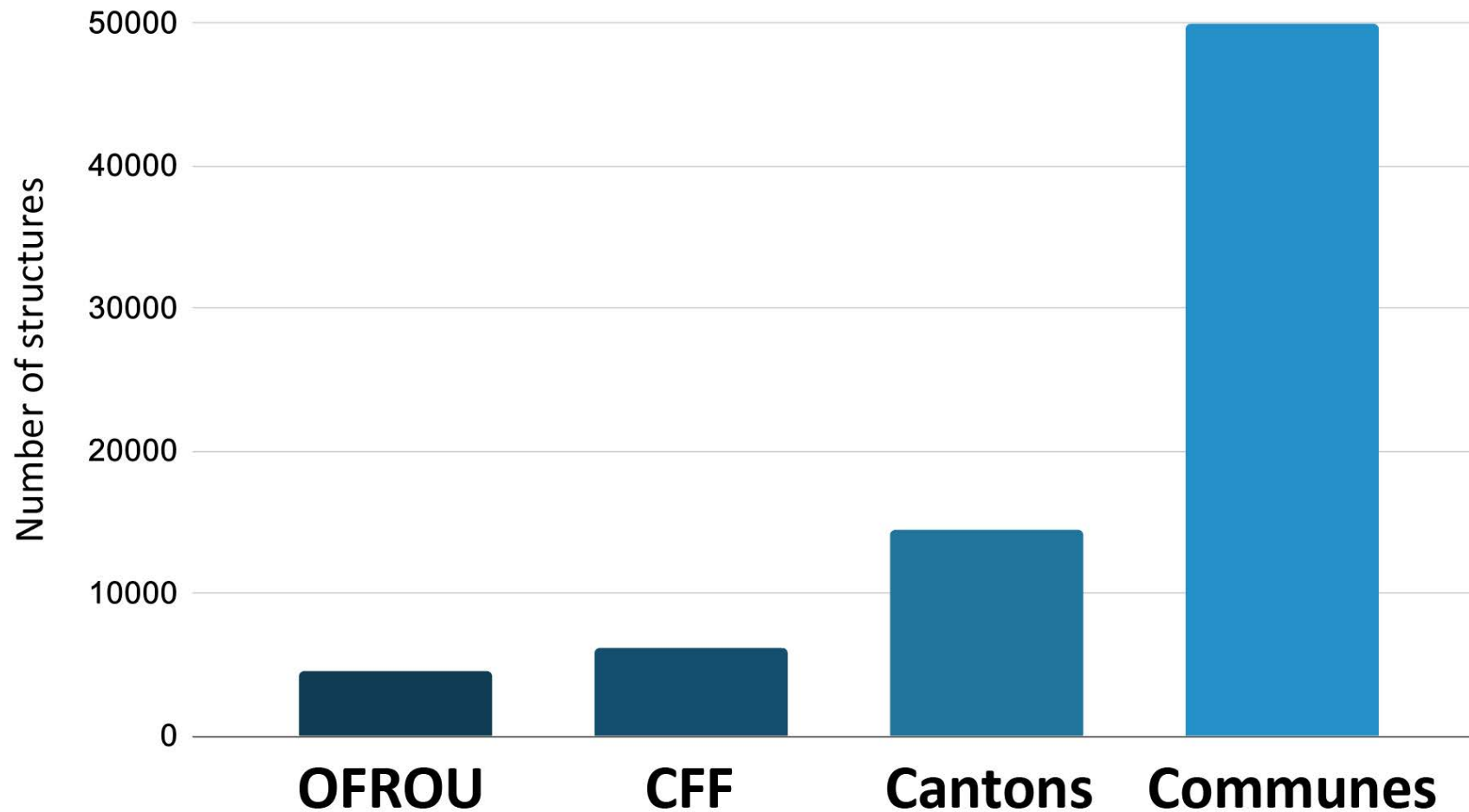

Future and perspectives

Annual maintenance Budget in Million CHF

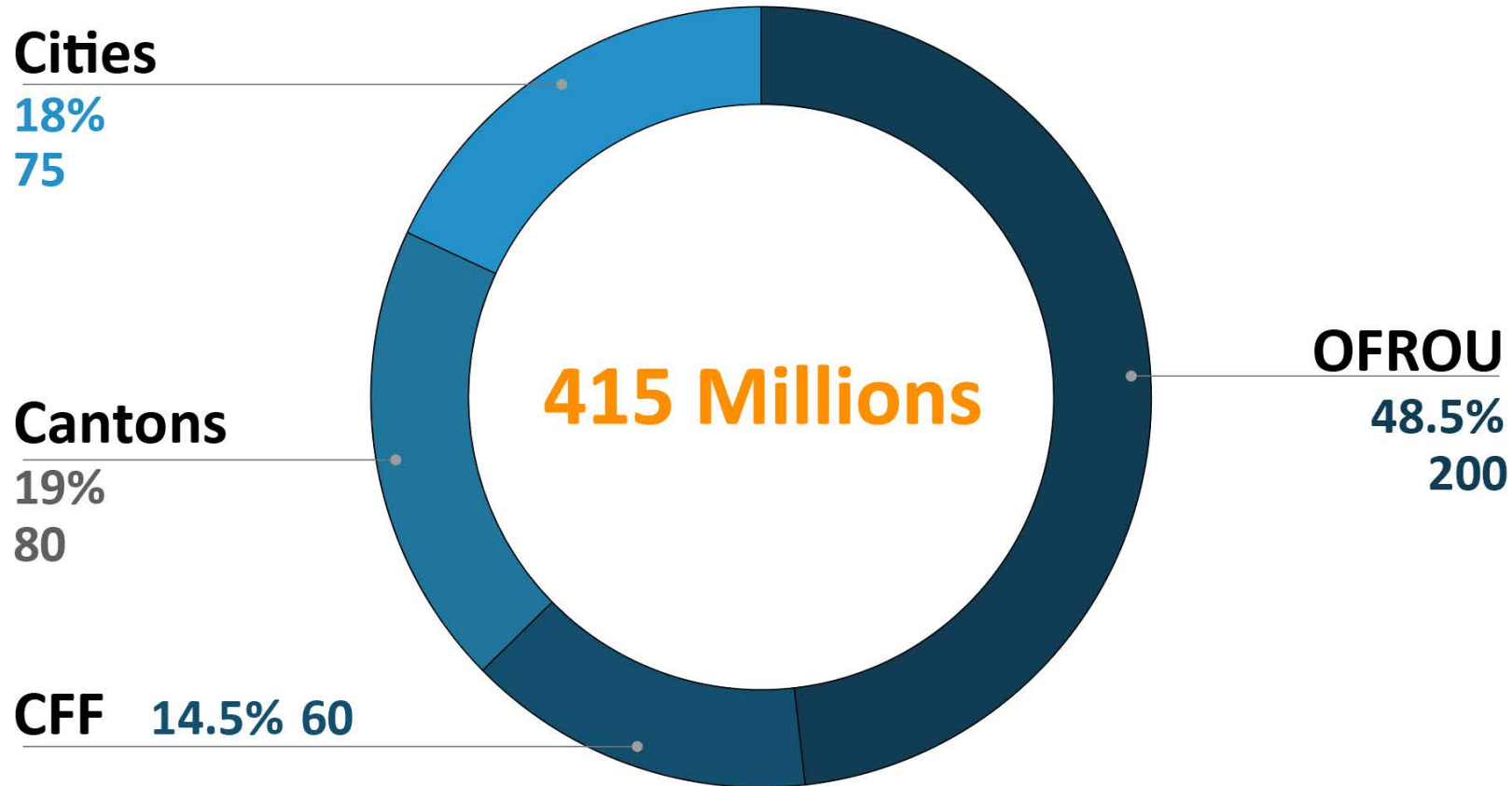

Future and perspectives

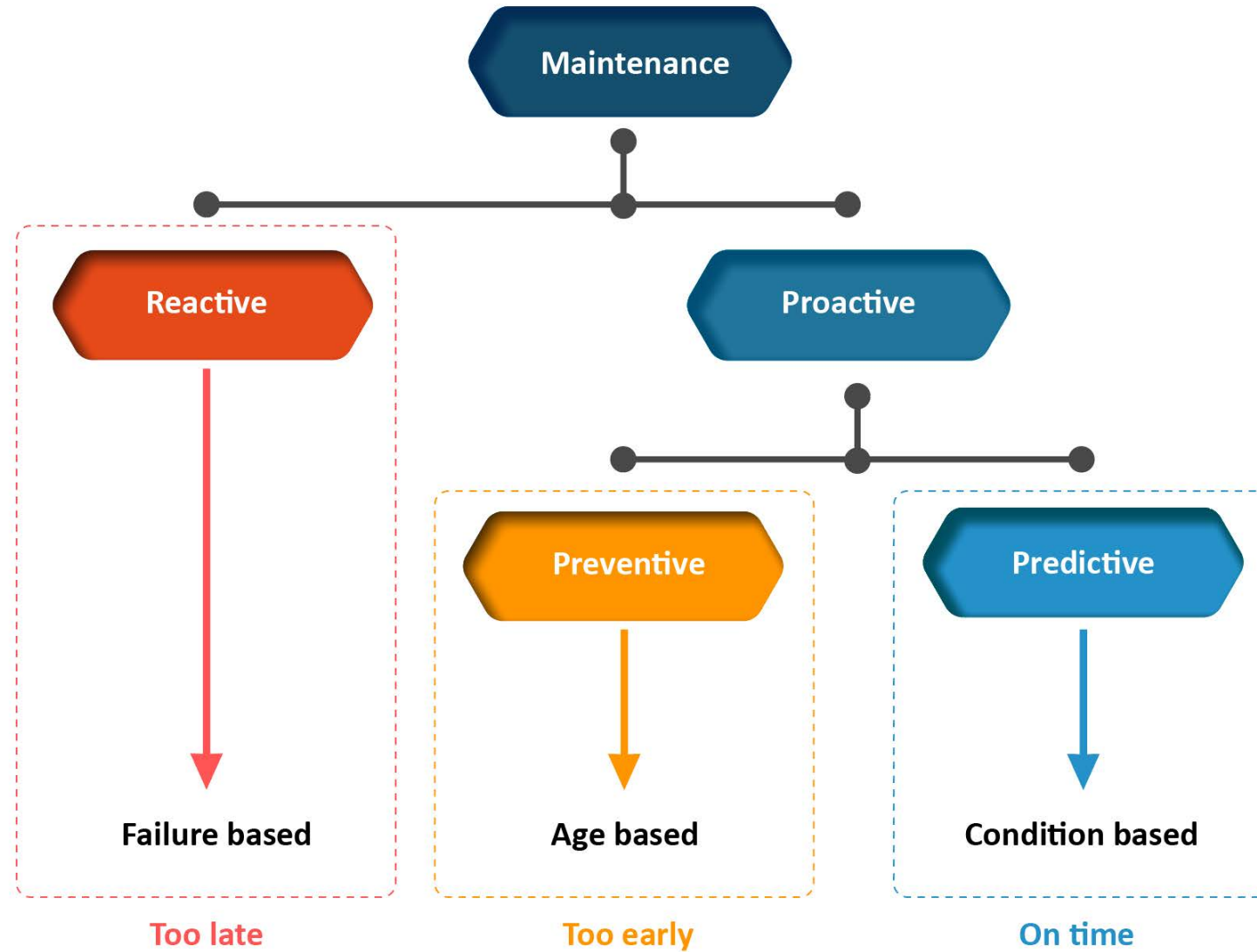

Ground Penetrating Radar - GPR



Ground Penetrating Radar - GPR

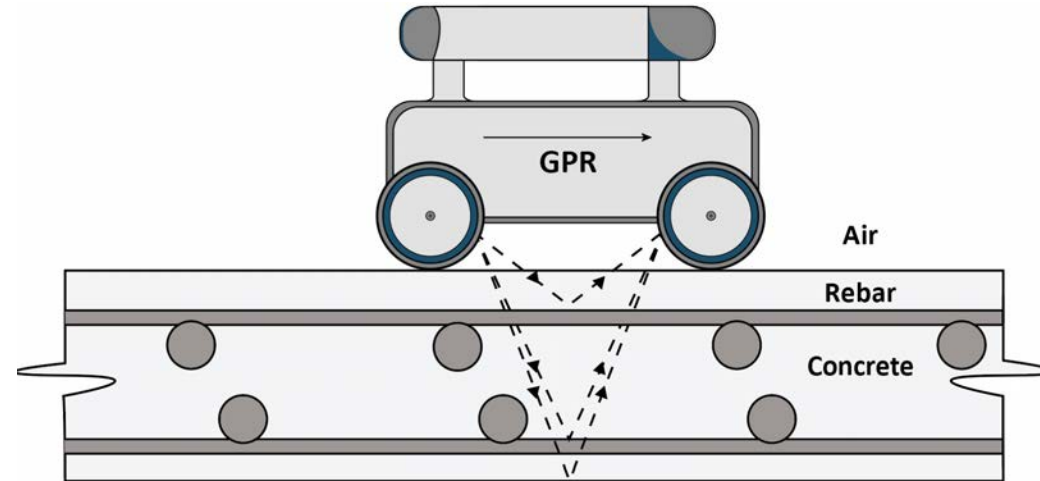

Data: Radargram

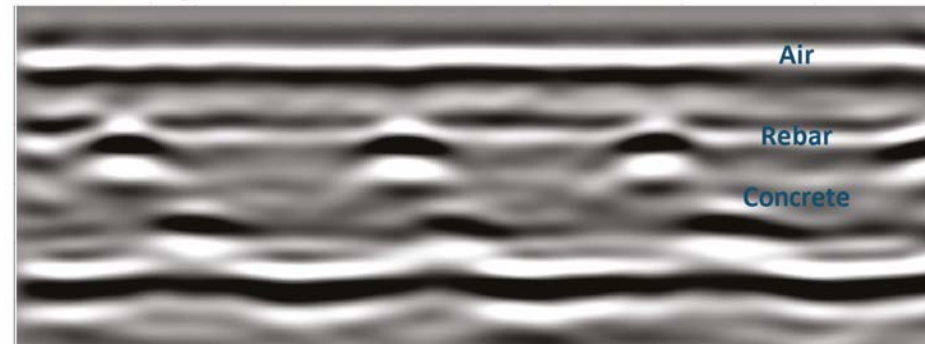

Theory

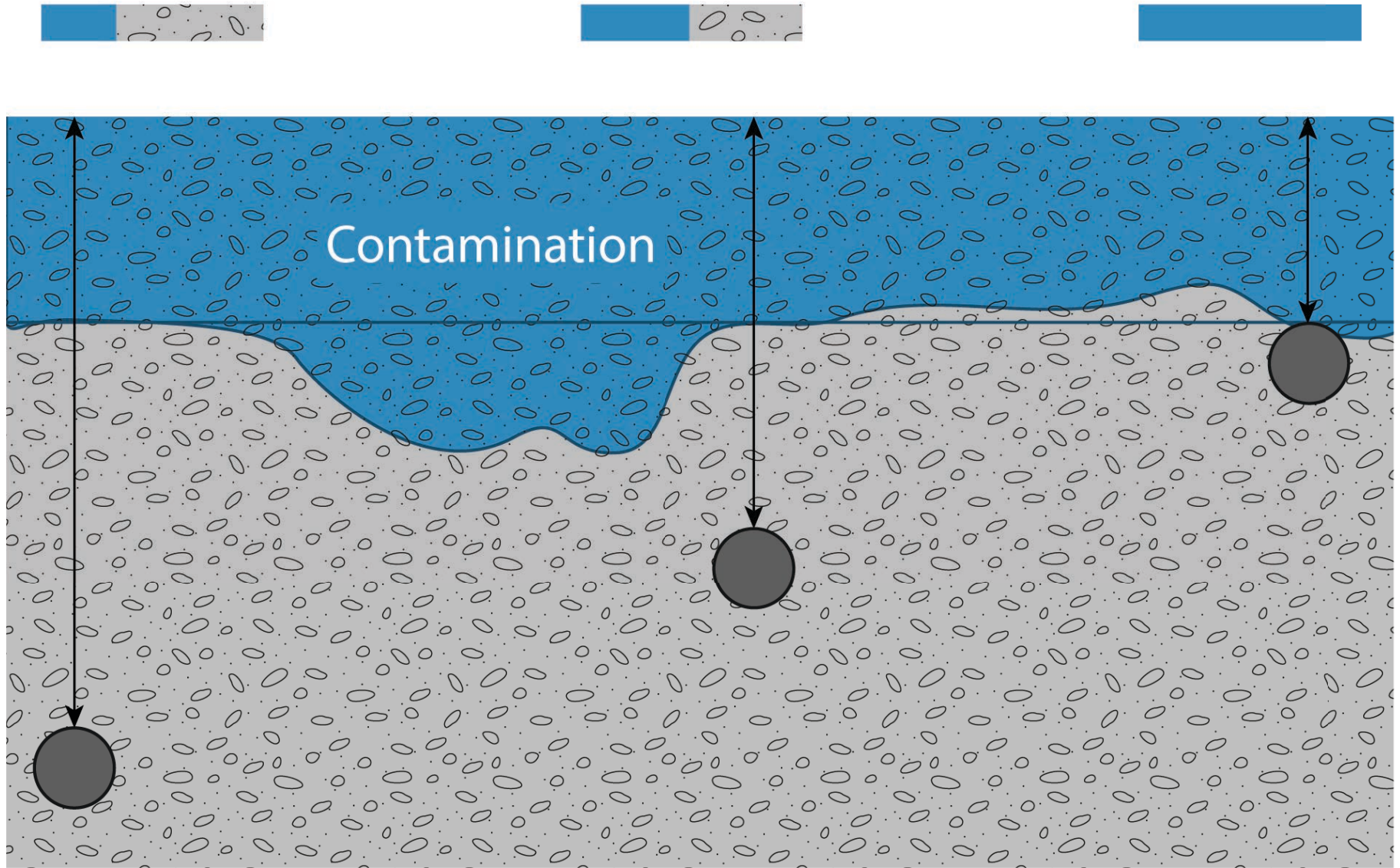

Results and Examples

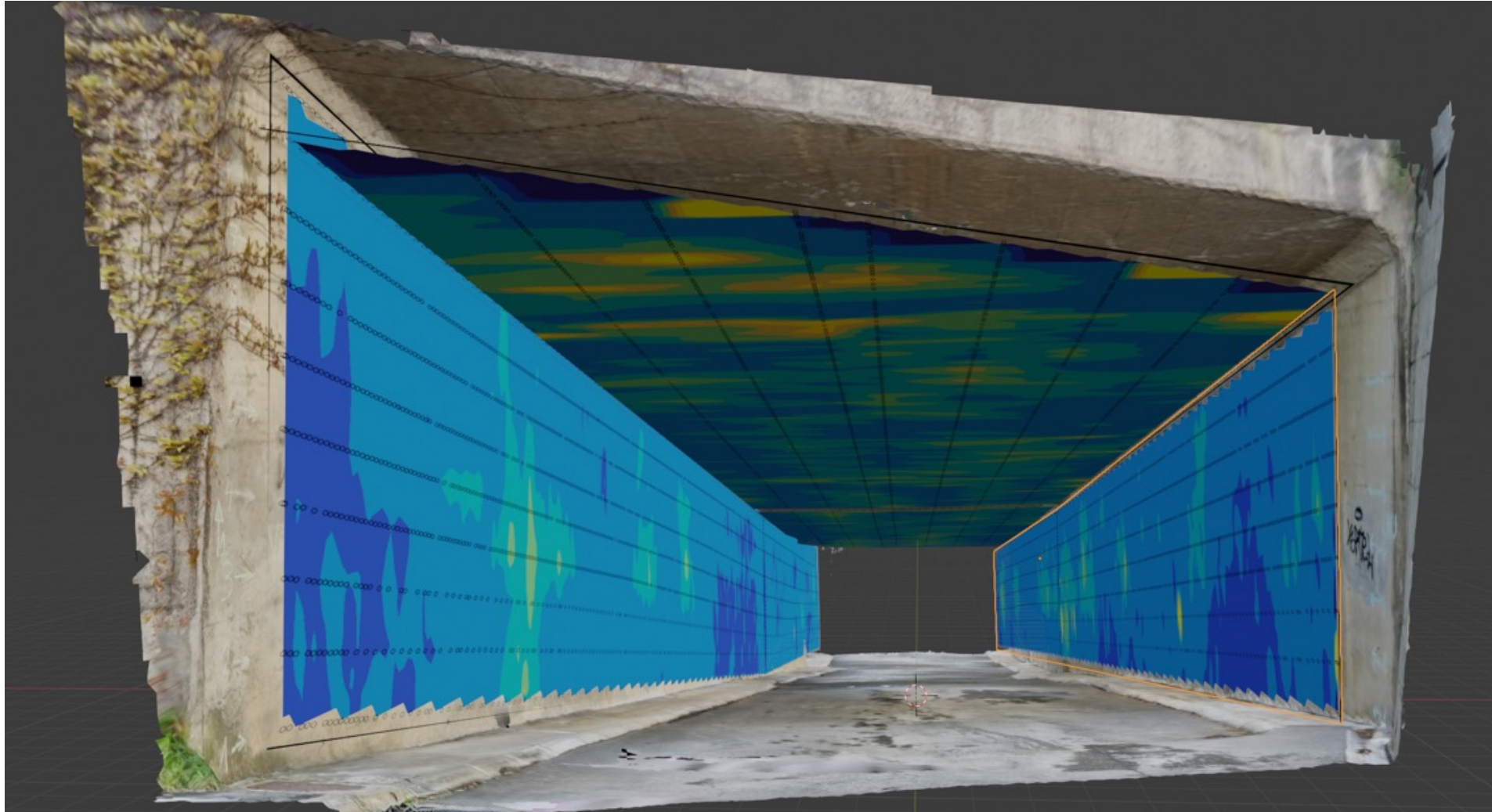

Structure mapping - Motorway Bridge

ASPHALT COVER THICKNESS

The thicknesses follow a normal distribution. The Northern bridge has slightly higher asphalt thickness than the Southern bridge: 10.3 cm vs. 8.6 cm. Both decks have large concrete curbs without surfacing directly exposed to chlorides.

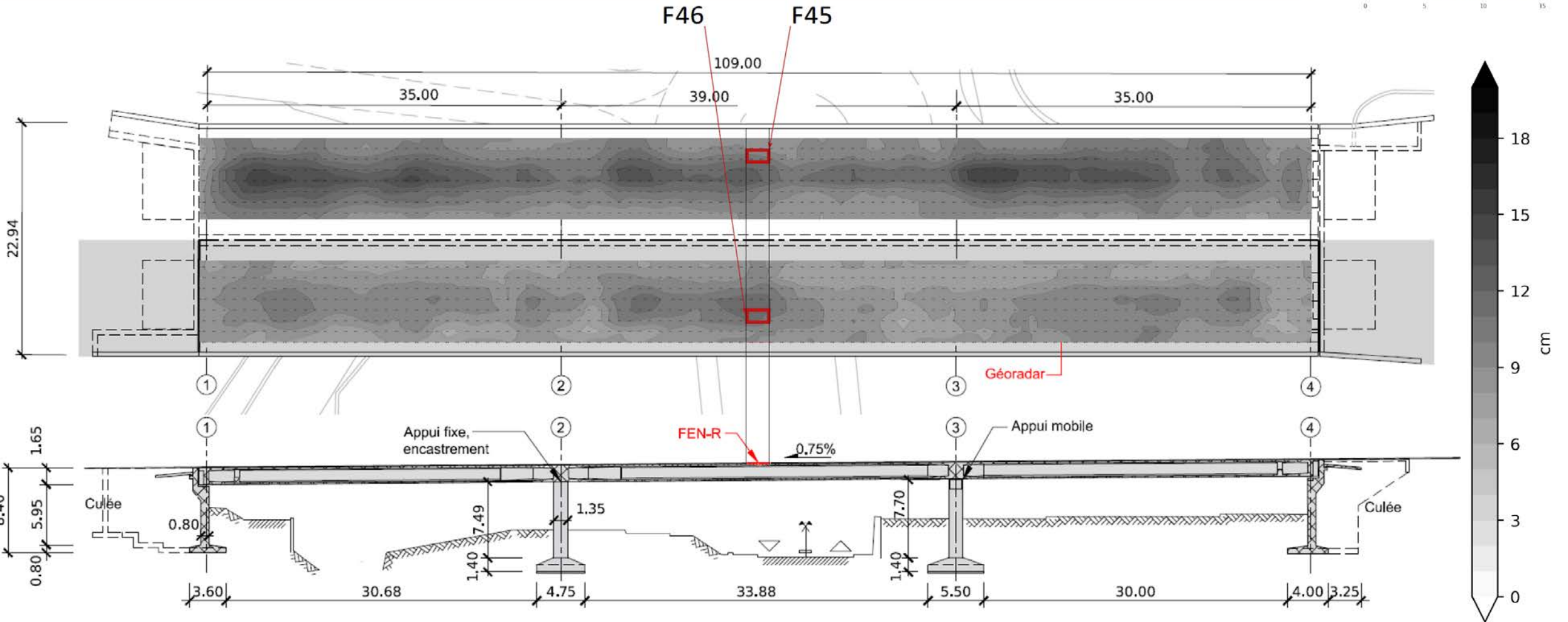
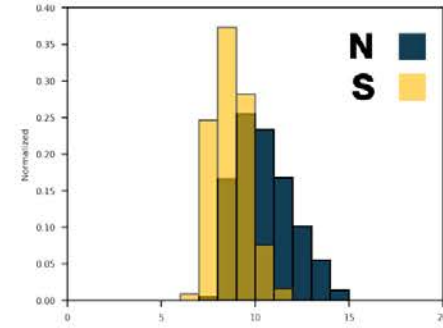

Structure mapping - Motorway Bridge

CONCRETE COVER THICKNESS

The measurements follow a normal distribution on both bridges. Both decks have significant under-thickness at the edges of the structure. This suggests that the reinforcement in the exposed areas is more vulnerable.

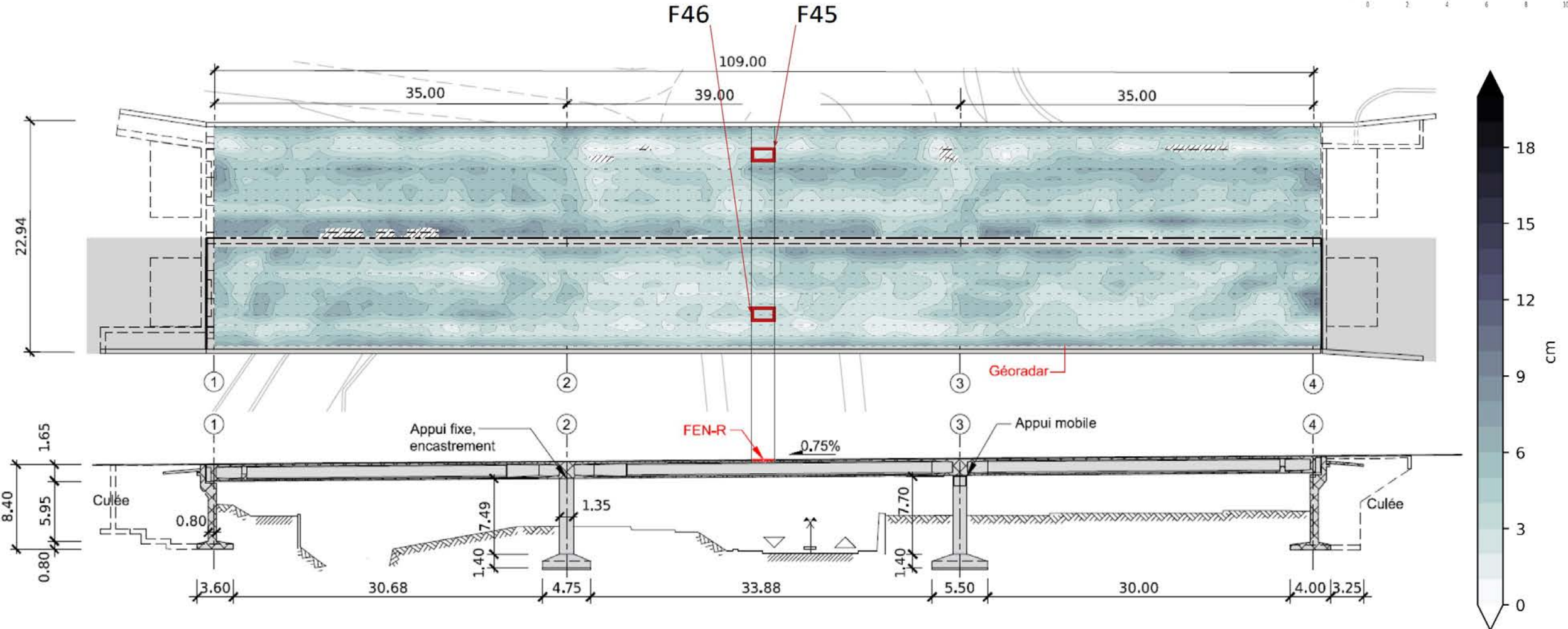
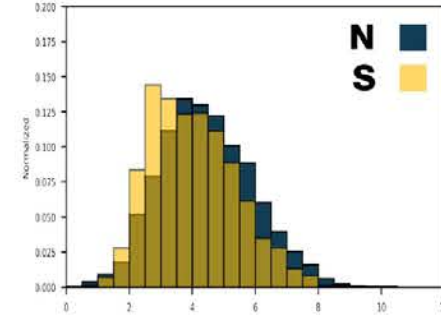

Structure mapping - Motorway Bridge

CONTAMINATION

Overall contamination is average. However, in detail, the North deck is heavily contaminated compared to the South deck.

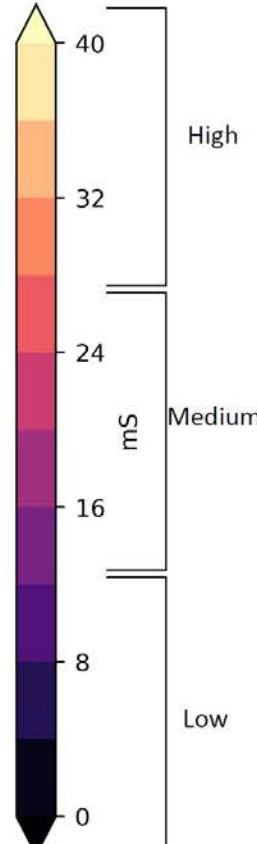
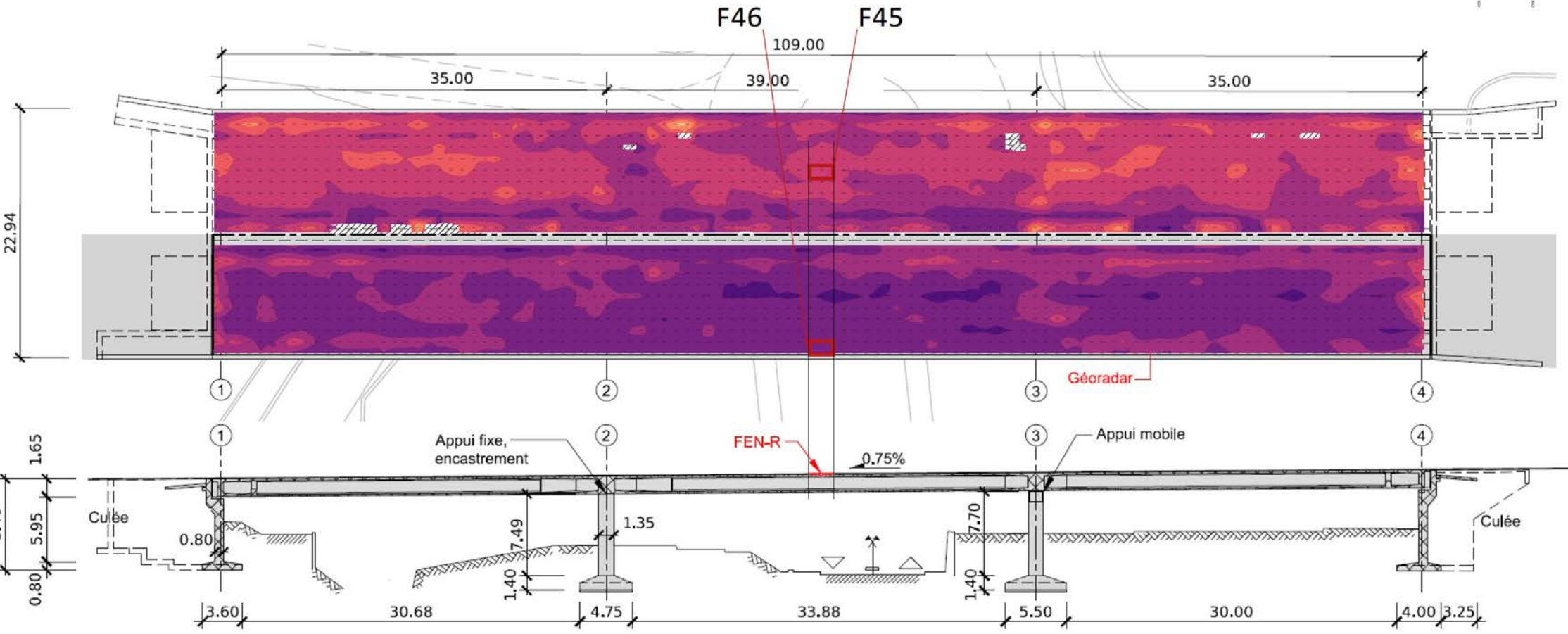
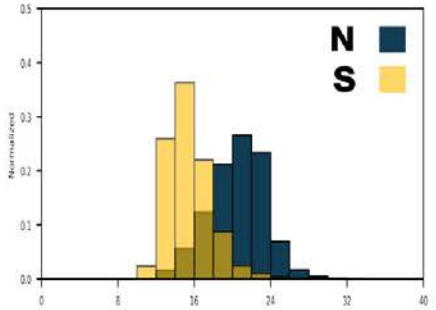

Structure mapping - Motorway Bridge

CORROSION RISK

The overall risk of corrosion is medium. However, our analysis reveals areas with a high risk of corrosion, mainly at the edges of both decks where the cover concrete is low. The generally higher values from the Northern deck are due to the presence of a noise reduction wall at the Northern border.

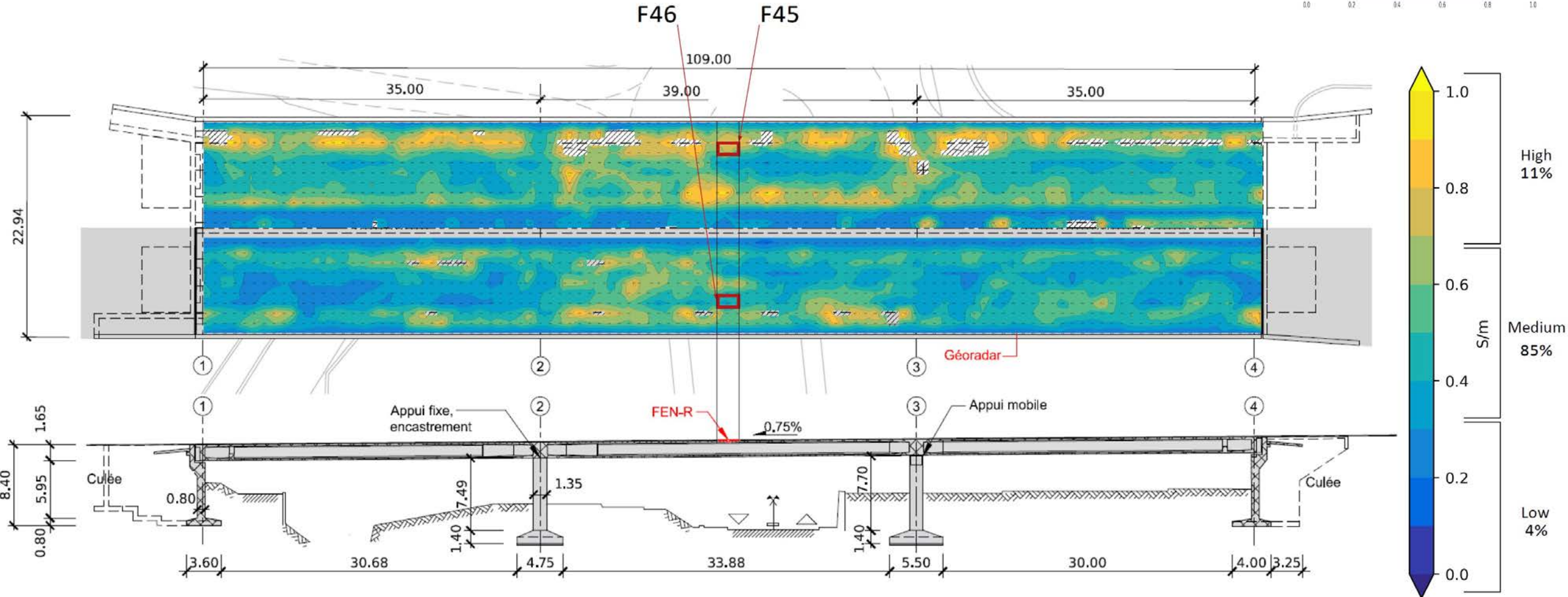
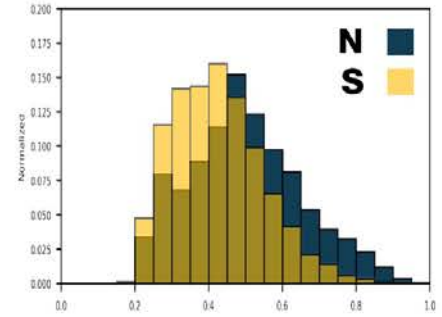

Structure mapping – Motorway Bridge

ADDITIONAL VERIFICATION AND CONFIRMATION OF CONTAMINATION

The structure having transverse prestressing, probing had been planned.

The first F46 probe was carried out in a low-contamination area.

Following signs of strand corrosion as well as high contamination values on the north deck, we recommended the opening of a second, initially it was an optional survey.

The F45 survey on the other deck confirmed the assumptions.

It was concluded that the exposed edges served as points of entry and accumulation of chlorides in the transverse prestressing ducts.

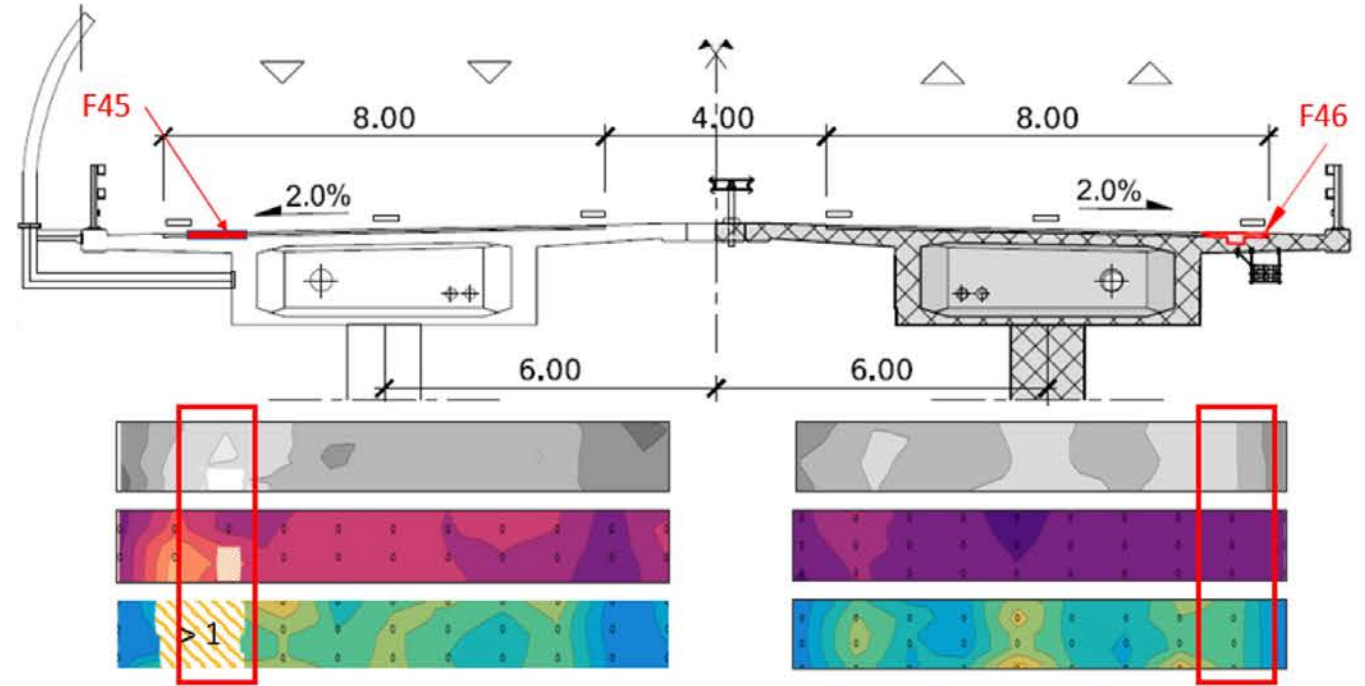

Evaluation	Characteristics	Evaluation
Green	Carbonatation	Green
10 [mm]	Concrete Cover	Green 32 [mm]
2.34[%]	[Cl-]	Green 0.06[%]
Green	Rebar condition	Green
Green	Strand condition	Green
Green	Waterproofing	Green
Green	ASR Top	Green
Green	ASR Bottom	Green
Green	Microstructure	Green
Green 50 MPa	Resistance	Green 44.2 MPa



Structure mapping – Tunnel

METHODOLOGY

A series of 9 longitudinal profiles of 135 [m] at the nacelle. The traffic interruption lasted 2 x 6 hours. The measurement density was determined to maximise the area inspected and form a realistic compromise between the measurement time and the accuracy of the final result.

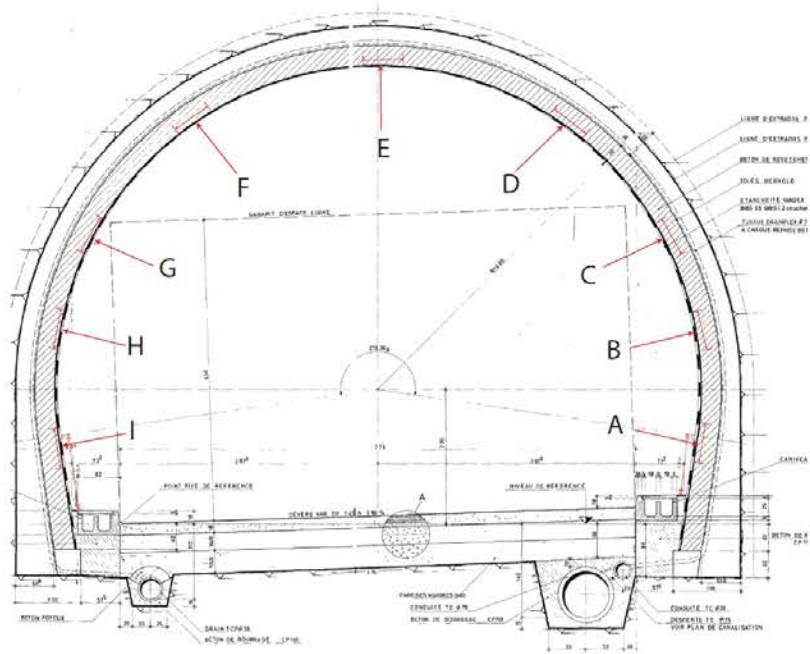

OBJECTIVES

The first part of the study consisted of measuring the facing thicknesses of the structure in preparation for the renovation work.

As the structure showed signs of degradation due to water circulation. The objective of the study was to determine the points of accumulation and weakness of the cladding.



Structure mapping - Tunnel

OBSERVATIONS

Link between the risk of detachment and the change in geological layers.
A particularly degraded area is observed at the western portal.

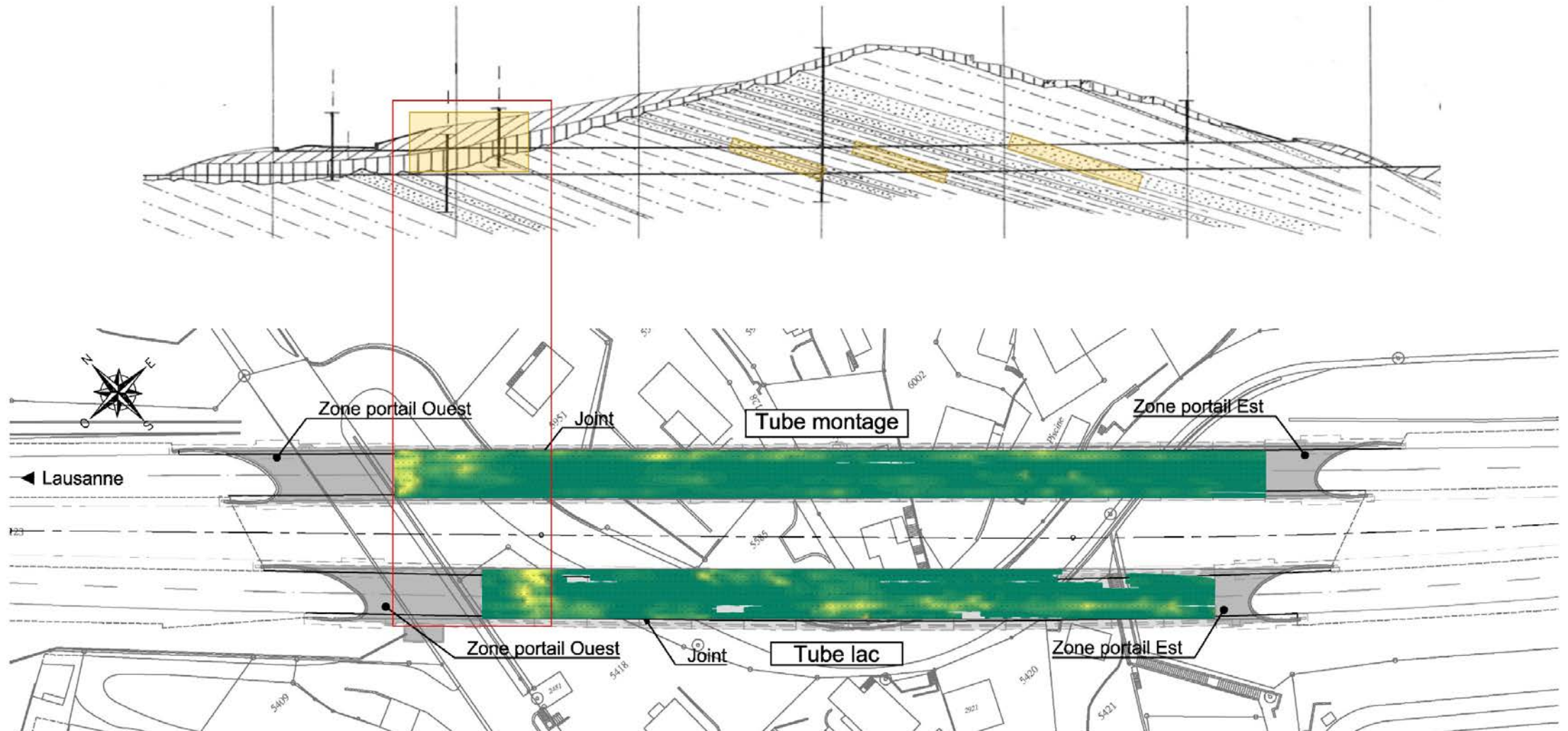

Structure mapping – Tunnel

OBSERVATIONS

An area of soft ground is located between two roads, this area being at the apex of the infiltration observations. It could act as an entry point and reservoir, accelerating degradation.





AKSELOS

Digital Twins of Large Infrastructure

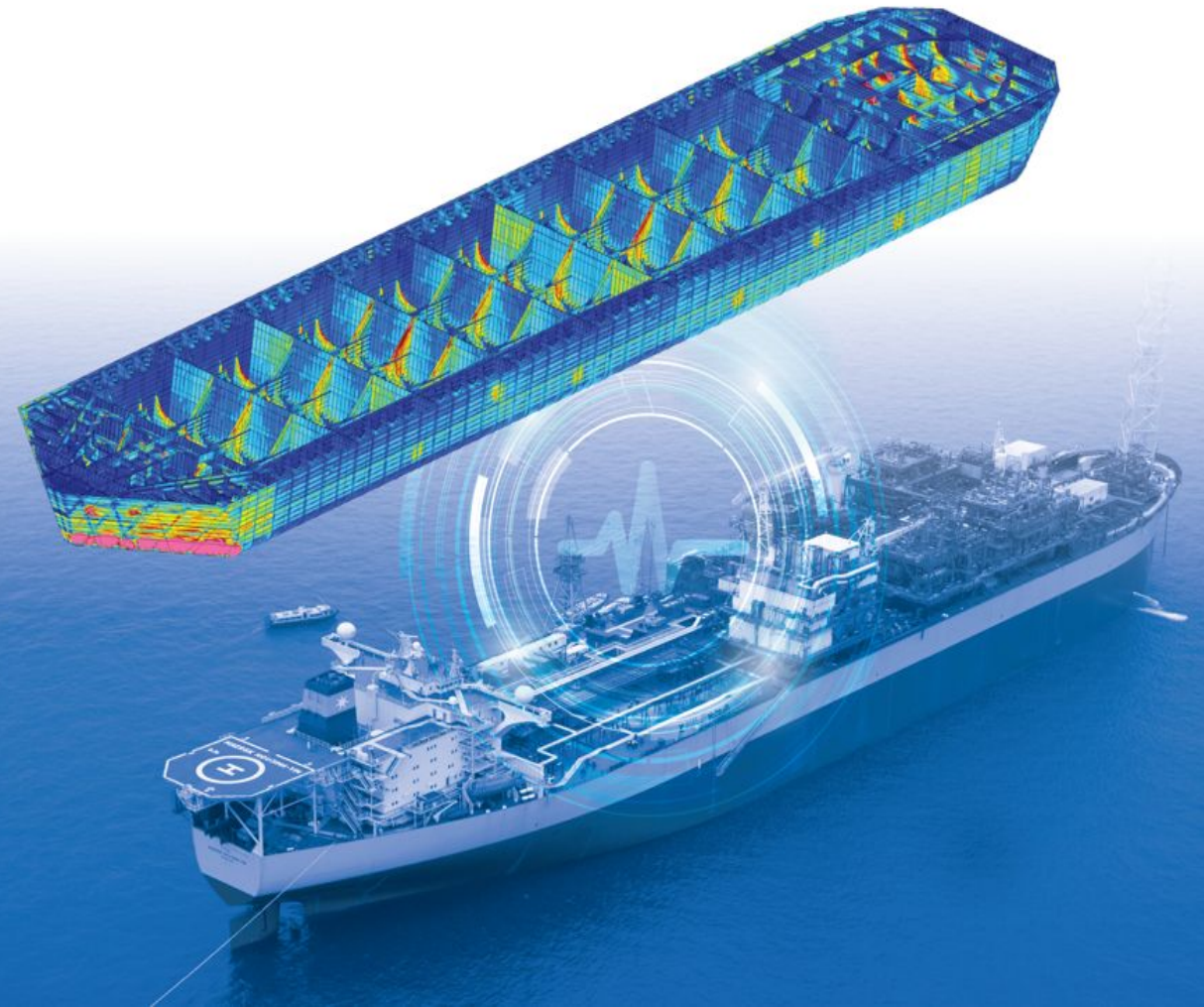



Shell
Ventures

INNOGY
VENTURES

\$10M INVESTMENT

● LONDON

● LAUSANNE

● BOSTON

HOUSTON ●

● HO CHI MINH CITY

12 YEARS OF RESEARCH AT MIT
BEHIND PATENTED ALGORITHMS

- 1. Digital Twin Context**
- 2. Technology Overview**
- 3. Examples and Case Studies**
- 4. Mathematical Background**



Akcelos's Take on Digital Twins

Digital Twins of large and critical engineering systems, e.g:

- Offshore structures for oil & gas (FPSOs, tankers, semisubmersibles, platforms)
- Rotating machinery (compressors, turbines, mills)
- Wind farms
- Mining machinery
- Civil infrastructure (bridges, buildings)



Akselos's Take on Digital Twins

Operators face a number of significant challenges with systems of these types:

- Systems are large and complex, deployed for decades, often operated beyond original design life
- Failure leads to safety and environmental risks
- Downtime is extremely costly in terms of lost revenue and repairs
- Reliability is driven by structural integrity issues such as structural fatigue, buckling, and cracking
- Inspection and maintenance is often based on ad hoc rules with significant uncertainty and which require engineering judgement and interpretation

Akselos's Take on Digital Twins

To meet these major challenges, heavy industry is increasingly looking toward Digital Twins to provide **quantitative** guidance for the inspection, maintenance, and operation of critical assets

Akselos Digital Twin: Physics-based model of an **entire asset** which incorporates the **current condition** (e.g. based on inspection data), and enables **fast high-fidelity** structural integrity analysis, optionally linked to **sensor data** (IIoT)

WIND TURBINES

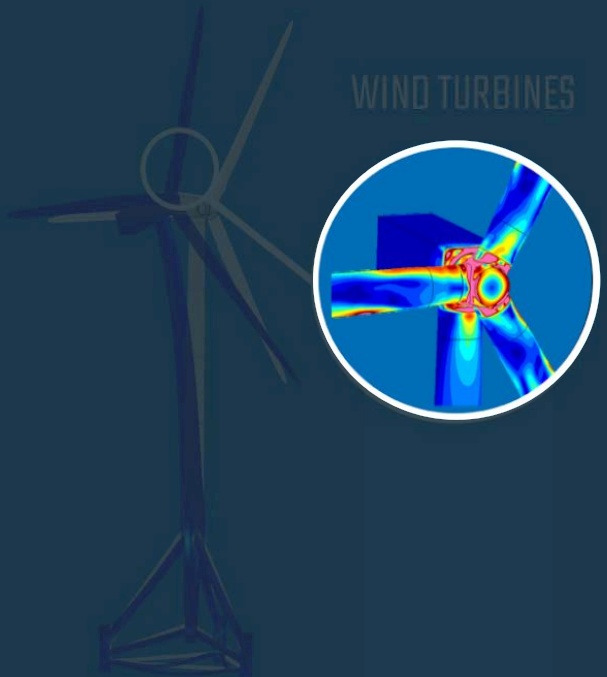

PRESSURE VESSELS



ROTATING MACHINERY

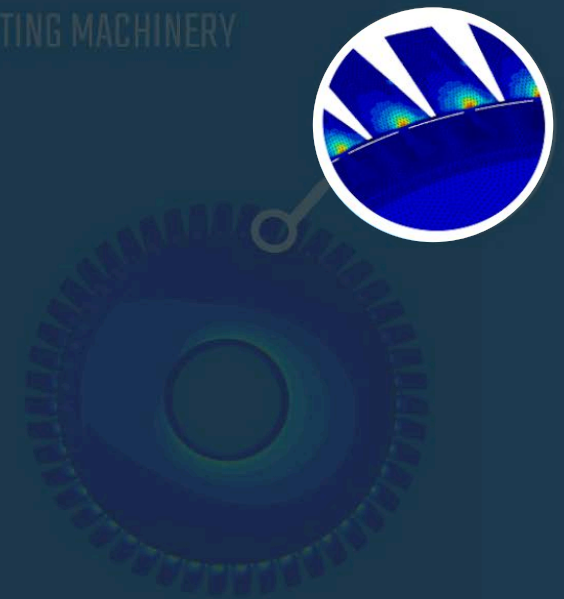

FIXED STRUCTURES

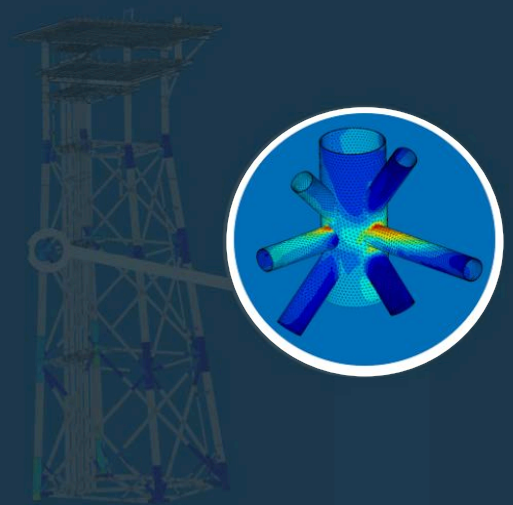

FLOATING STRUCTURES

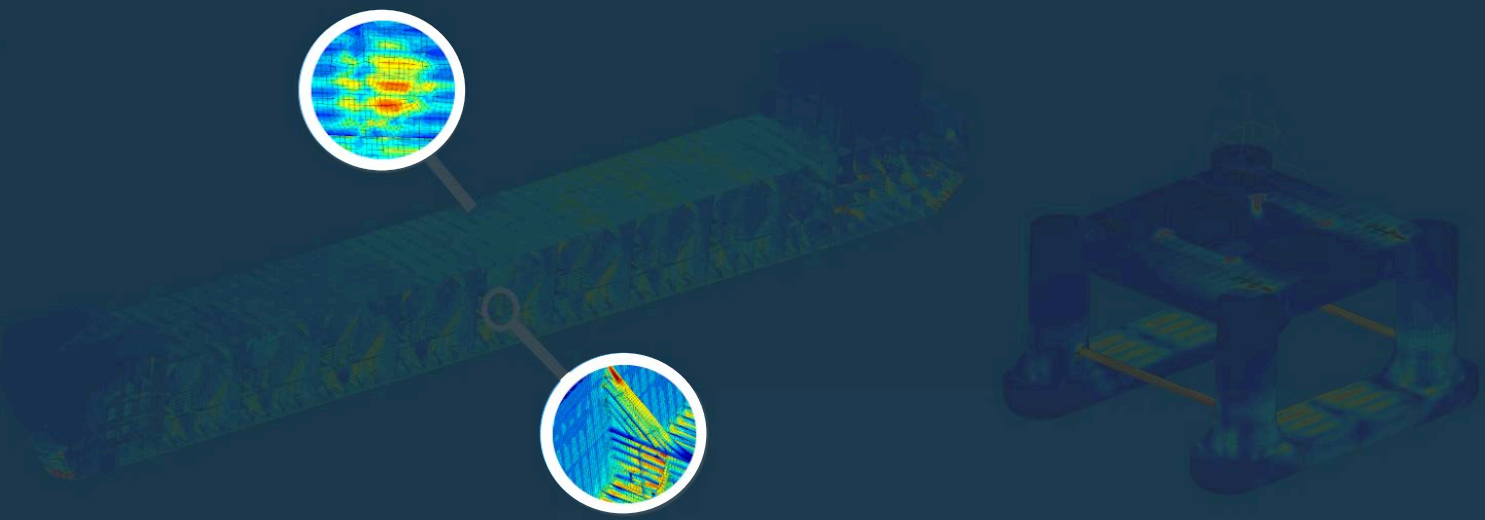

WIND TURBINES

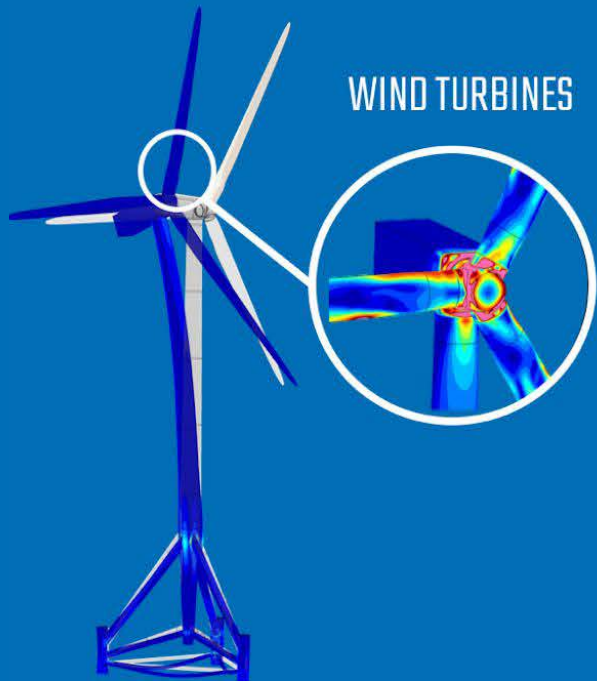

PRESSURE VESSELS

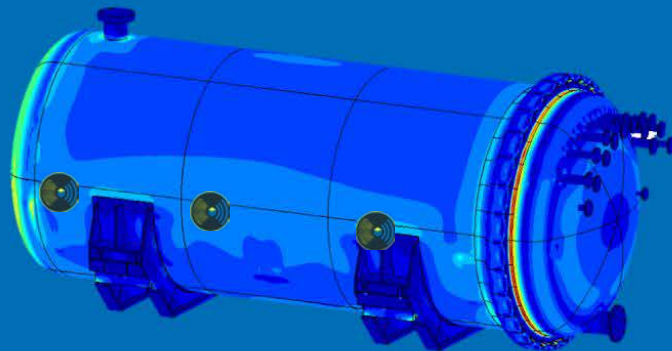

ROTATING MACHINERY

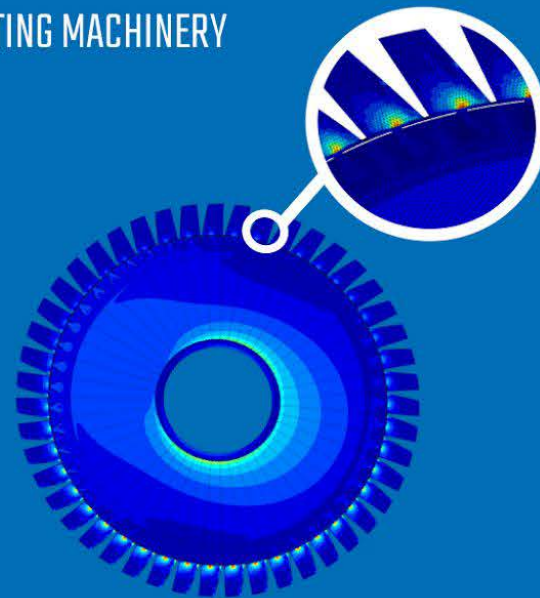

FIXED STRUCTURES

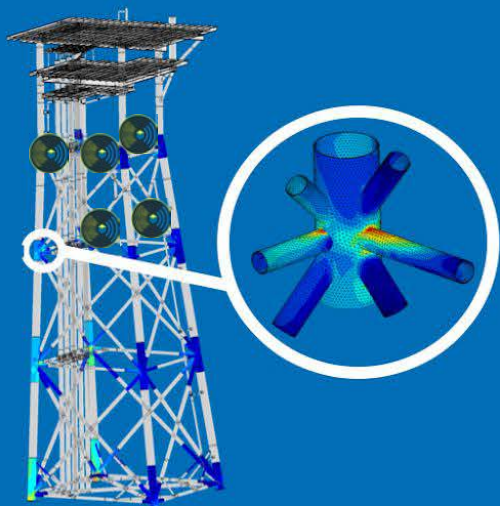

FLOATING STRUCTURES

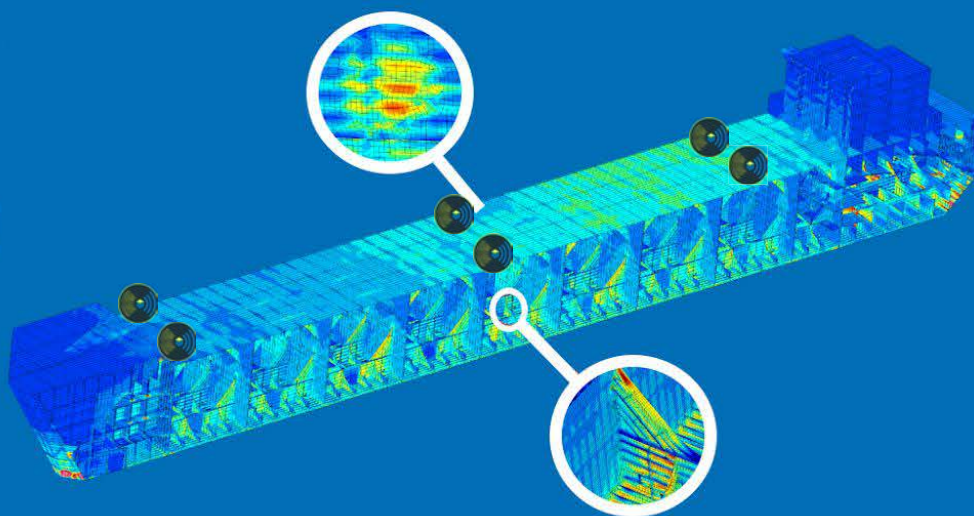

RISER/UMBILICALS

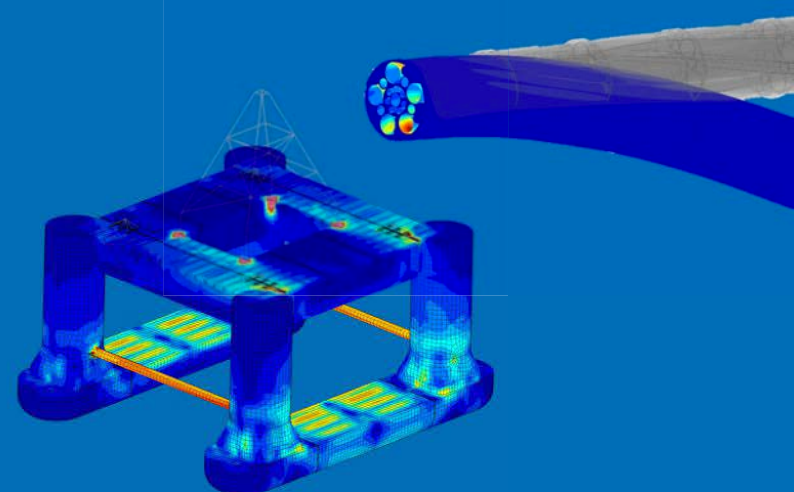

1. **Digital Twin Context**
2. **Technology Overview**
3. **Examples and Case Studies**
4. **Mathematical Background**



Akselos accelerates and “scales up” FEA via a new solver type: RB-FEA (Reduced Basis Finite Element Analysis)

- Component-based reduced order modeling
- Two-phase approach gives ~1000x speedup compared to FEA:
(1) **Component Pre-analysis** and (2) **Model Evaluation**
- Components are parametrized: change material properties, thicknesses, geometry, loads, and re-solve quickly

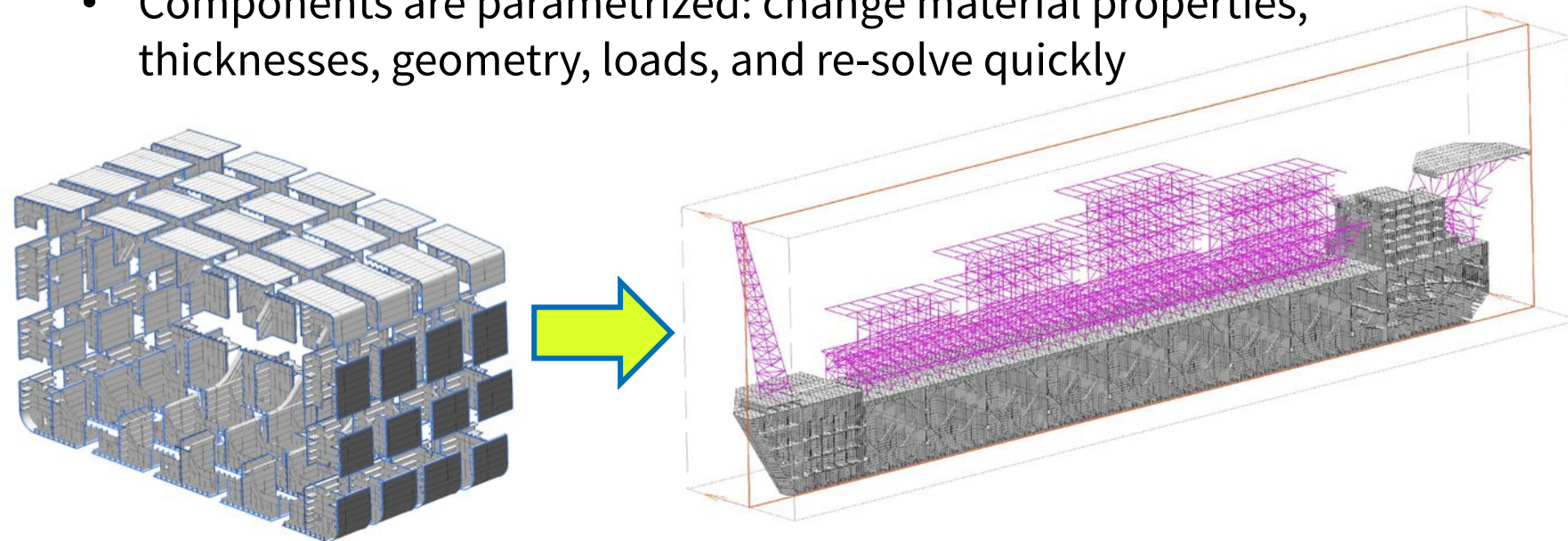

AKSELOS AT A GLANCE

MIT developed
technology protected
by issued patents

RB-FEA TECHNOLOGY
AT A GLANCE

100 academic
publications

AKSELOS AT A GLANCE

R&D funded by US
Department of Defence

Component Pre-analysis

- Automated FEA + postprocessing of components (individual and groups) to construct accurate reduced model of component physics and interactions
- **Performed upfront (during Digital Twin setup)**, datasets **stored** and **reused** over the asset's lifetime

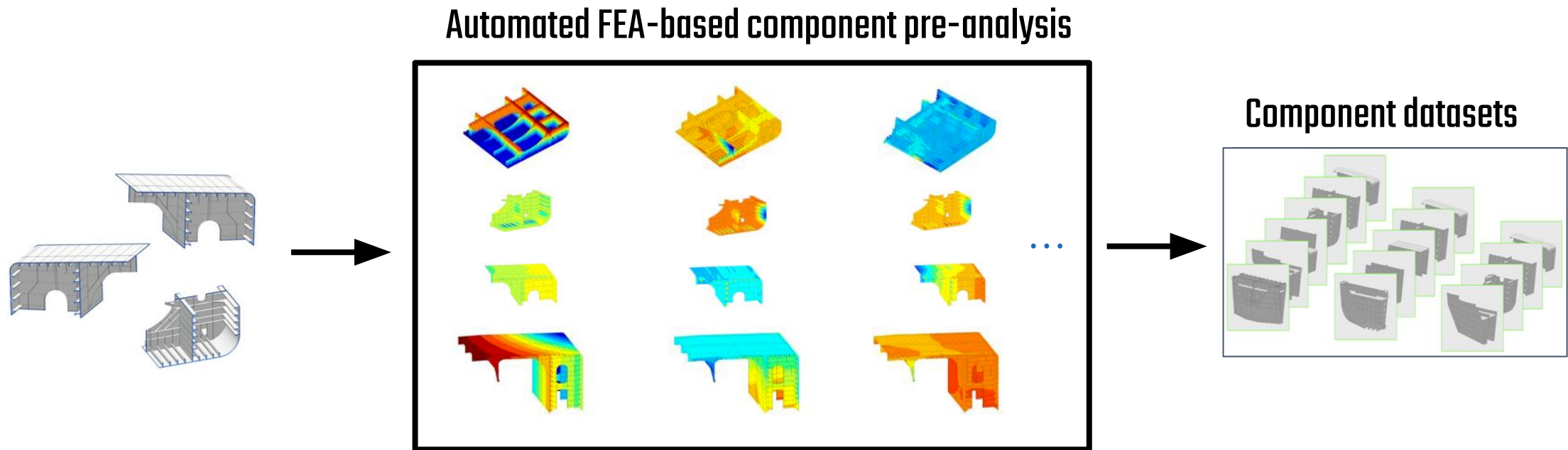

Components are Parametrized

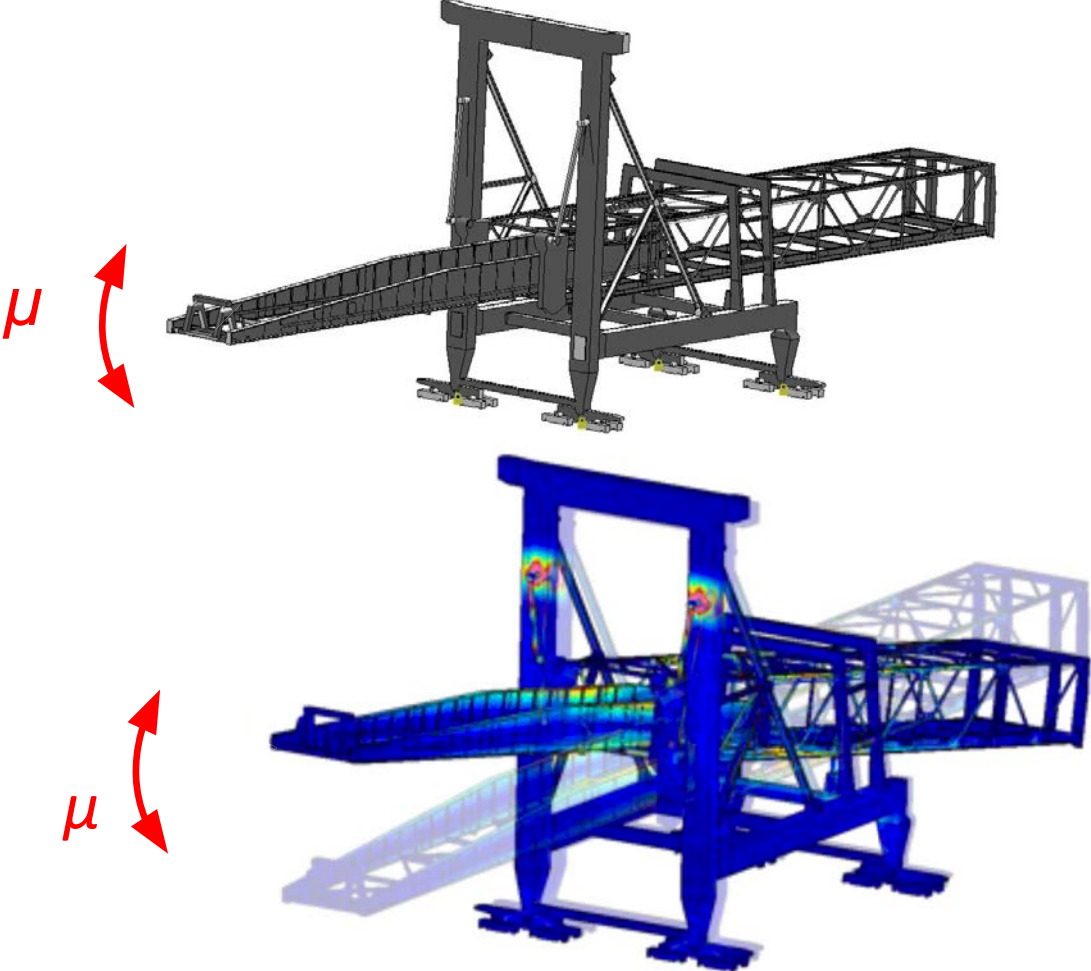
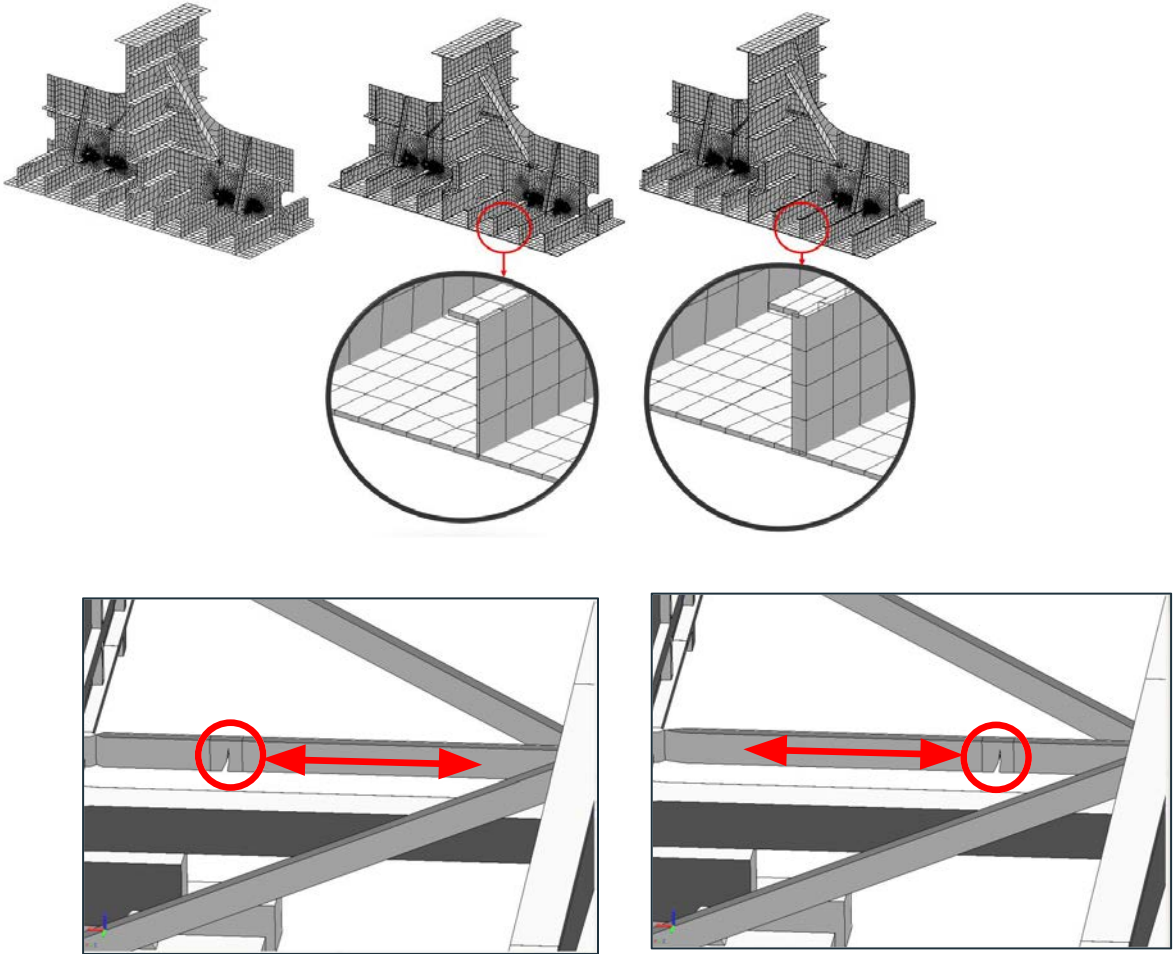

Akselos RB-FEA technology at a glance

1000X FASTER

Provides major speedup compared to FEA for linear PDEs, e.g. **>1000x** for large-scale problems

1000X LARGER MODELS

Easily solve models with **>100m** FEA DOFs. This enables true condition-based models of entire assets (Digital Twins).

PARAMETRIC

Modify models by changing parameters. Efficiently handles systems with many parameters, e.g. **>1000**

COMPONENT-BASED MODELING

Modular designs, easily add/remove/replace components

CLOUD-BASED PLATFORM

Provide all users with powerful computational platform via secure client-server architecture

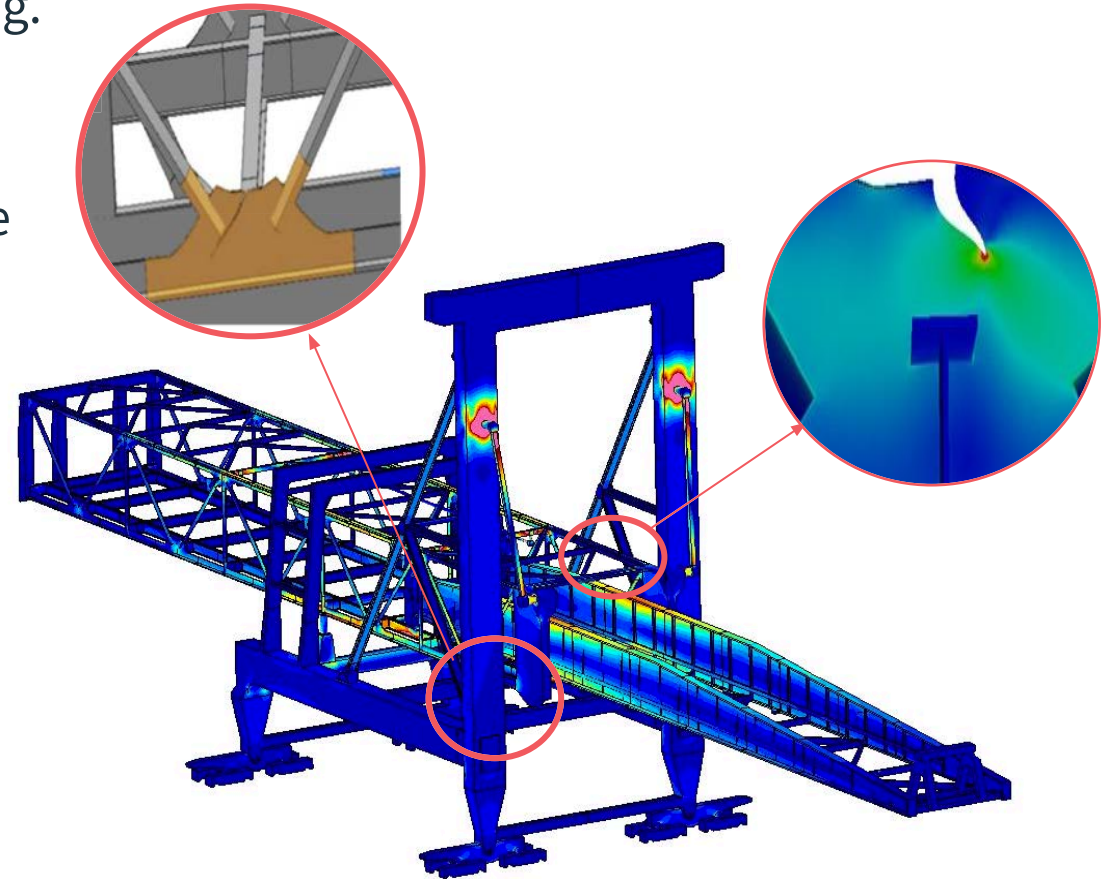

Integrates with the Digital Transformation Ecosystem

Open API (Python-based), open data formats, import/export data and models

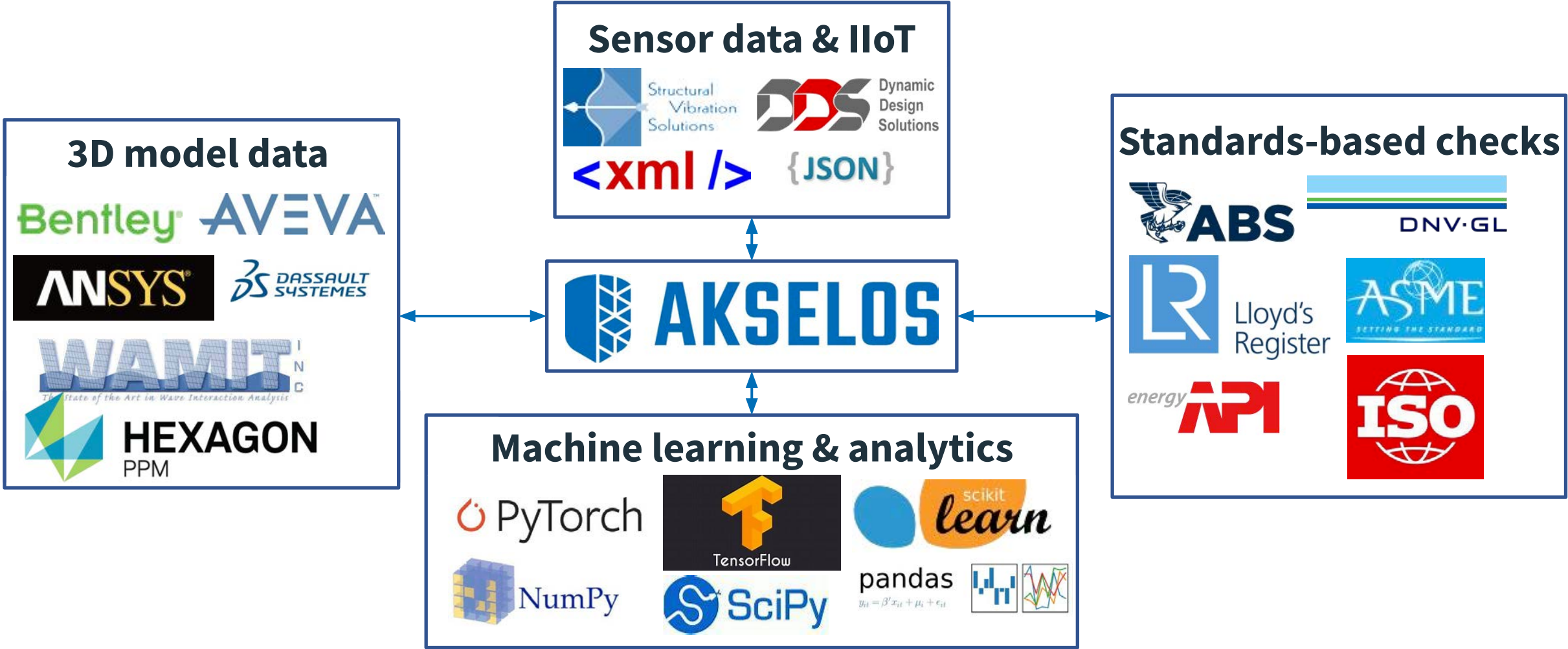

Akselos Cloud

Digital Twin-based Monitoring

View current status of each asset based on Digital Twin



Cloud-based digital twins for live asset monitoring from any office around the world



1. **Digital Twin Context**
2. **Technology Overview**
3. **Examples and Case Studies**
4. **Mathematical Background**



Example: Shiploader

FEA DoFs: 20 million (P2 TET elements)



RB-FEA: 166 components, 287 connections

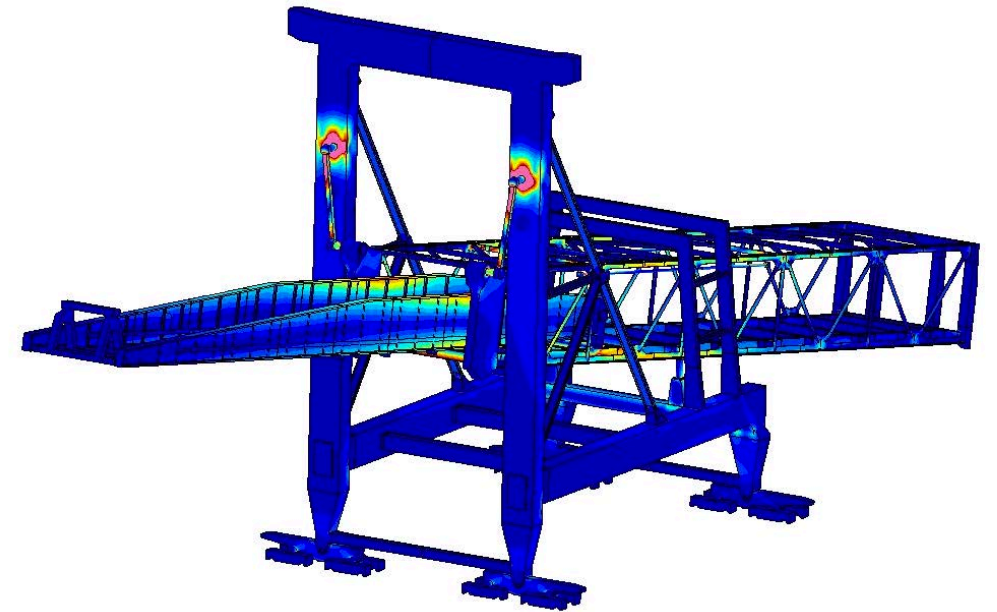

RB-FEA: ~ 1 second

Accuracy validated for submodels: < 1% wrt to FEA

Example: Windturbine

FEA DoFs: 9.8 million (MITC4 shell elements)

RB-FEA: 31 components, 36 connections

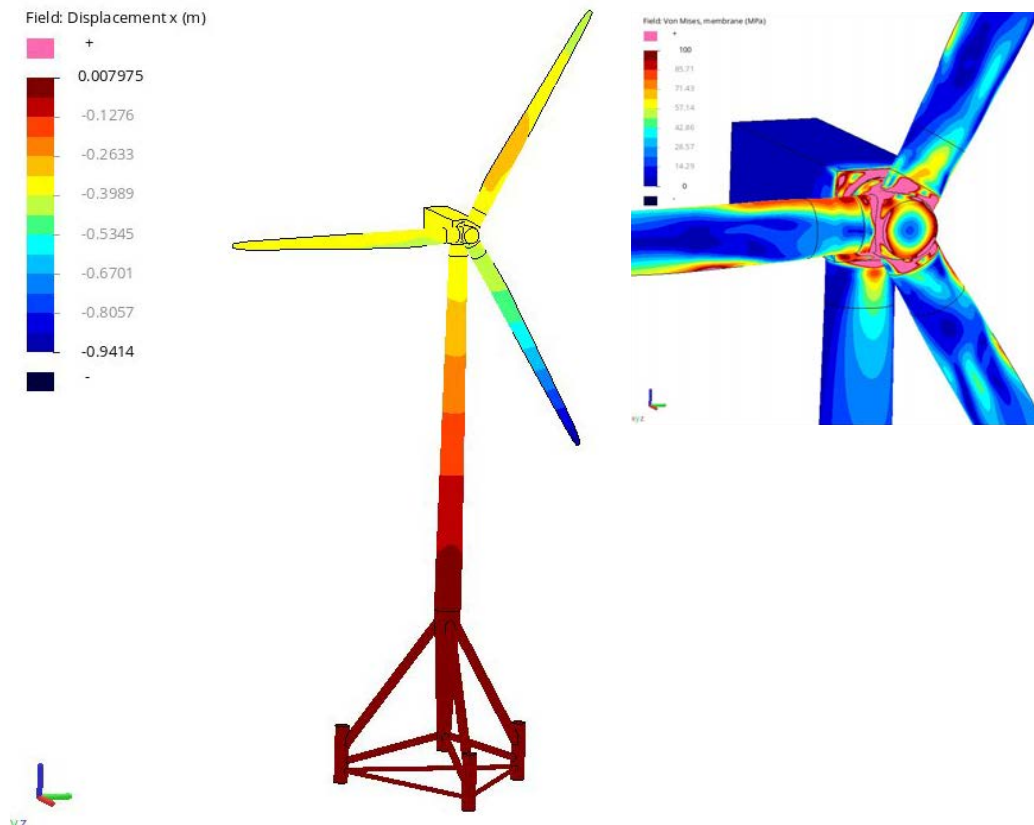

FEA: 155 seconds

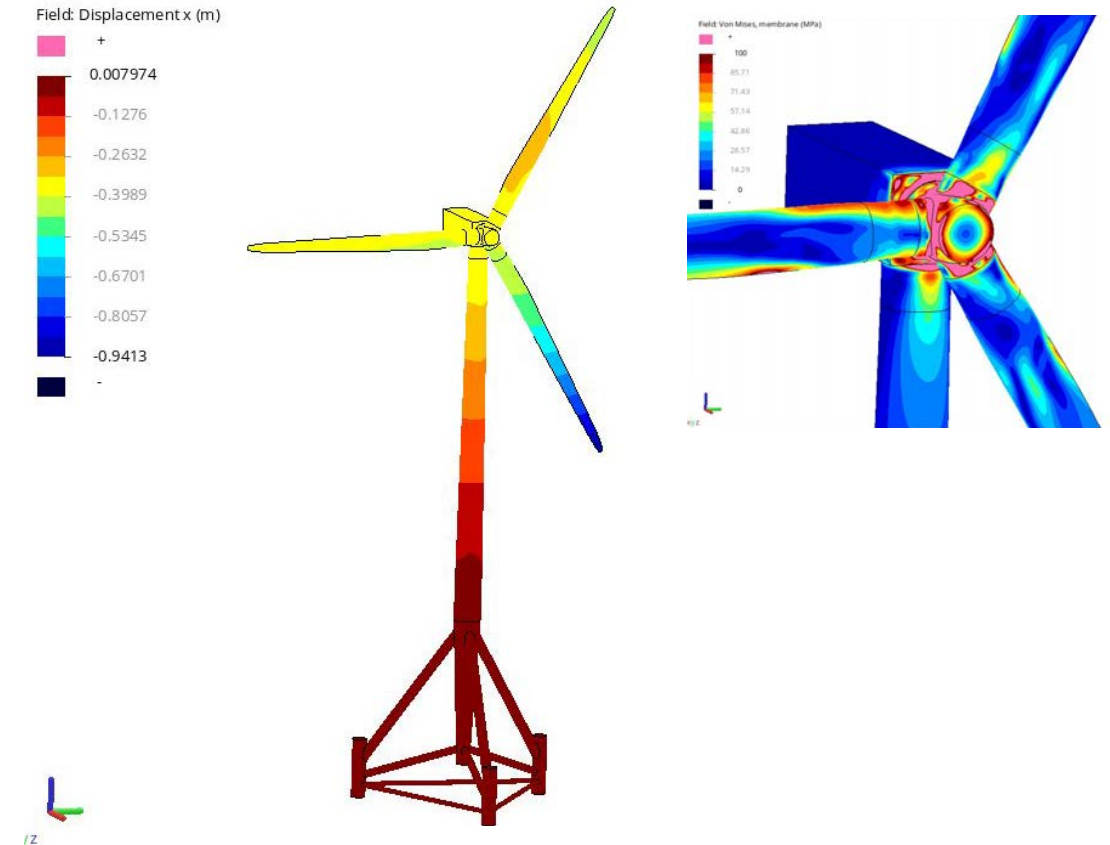

RB-FEA: 0.06 seconds

Life Extension for Offshore Platforms

Beam model

AKSELOS Model

VS

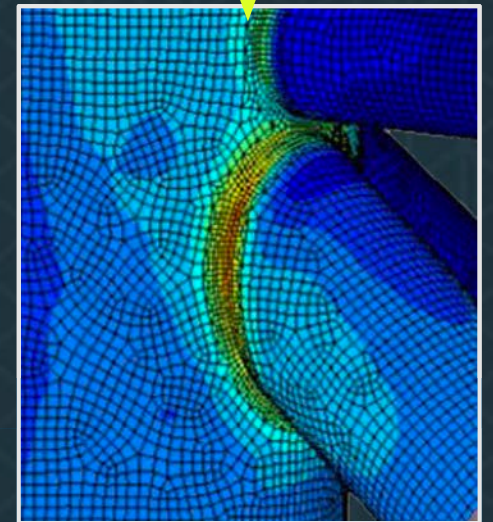
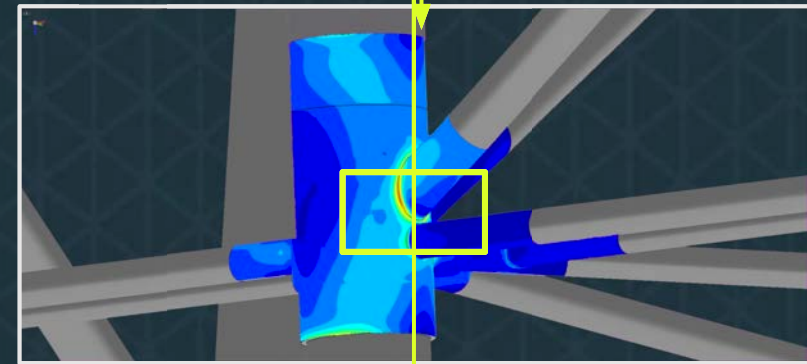
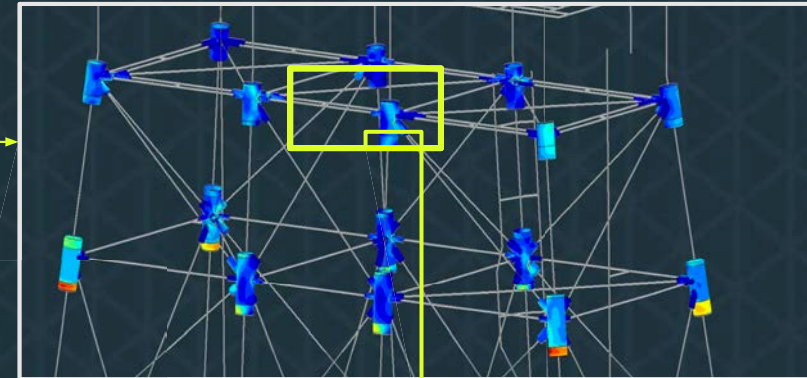
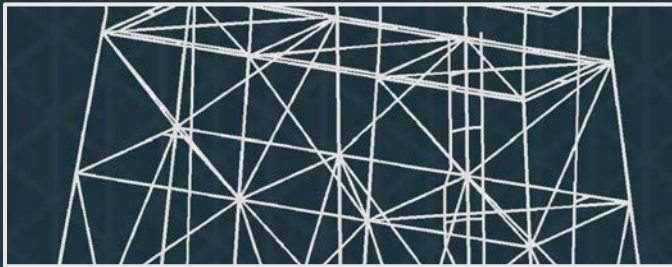

Also fully supported in Akselos Integra

With 3D joint mesh modeling

AKSELOS AND VALUE GENERATION – FPSO CASE STUDY



OPEX improvement

Reduce OPEX achieved by improving the quality and timing of the inspection; also reduced down time.

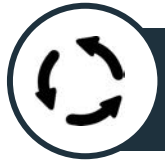

Life Cycle management

Further wins in cost improvement are achieved with decision support for the FPSO.

Case Study: Fixed Offshore Platform

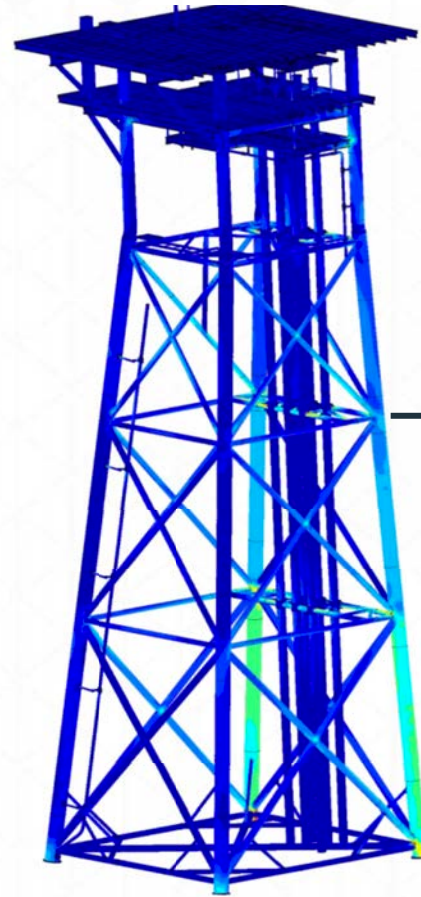

Digital Twin of Fixed Offshore Platform

- Large fixed Platform in UK sector of North Sea
- Long Field life expected for the Asset

Motivation:

- Extend Asset Life
- Improve operations and responsiveness
- Improved economics

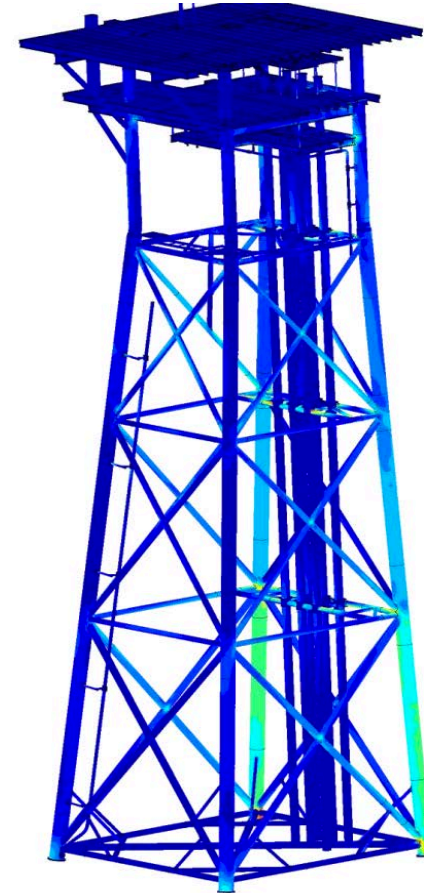

AKSELOS DIGITAL TWIN: BUILD AND RUN

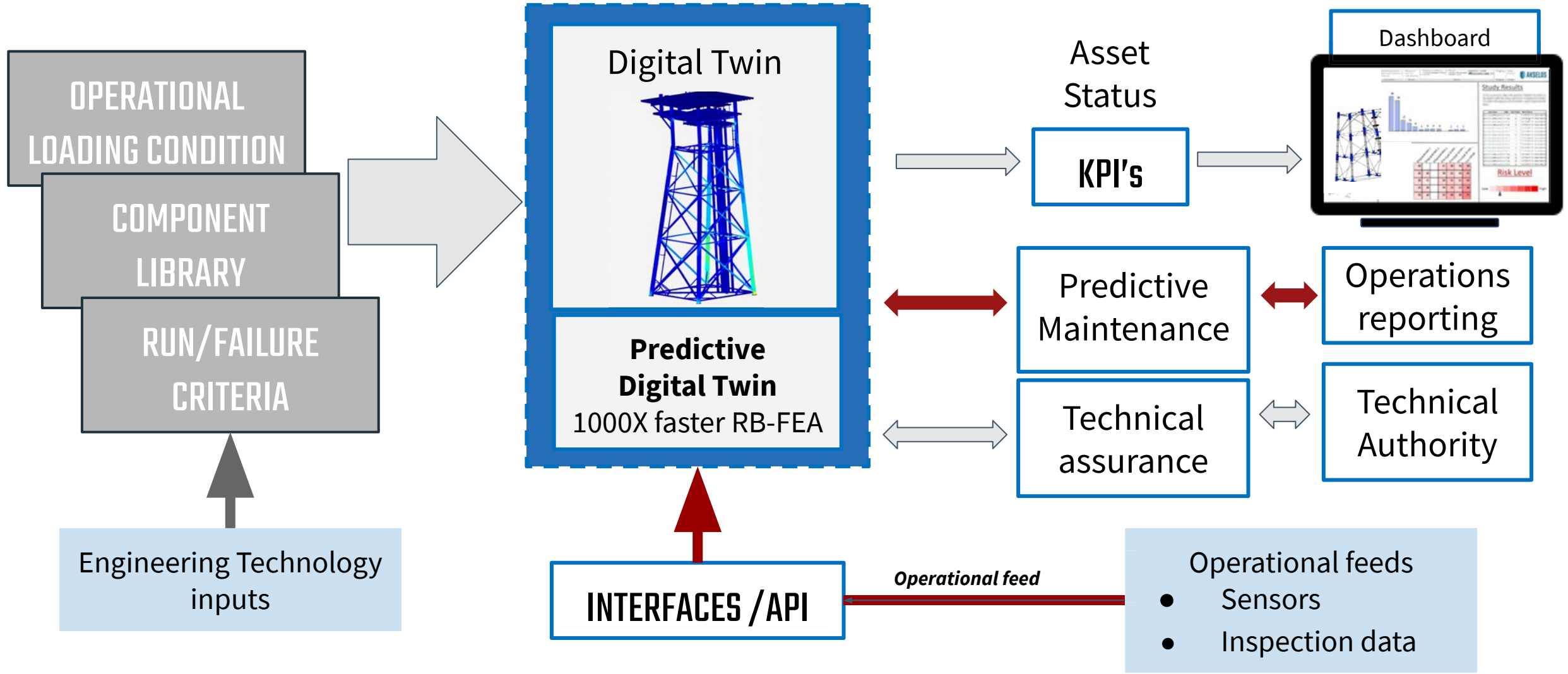

TRUE REPRESENTATION IN REAL TIME (1/4)

1. Create high-fidelity Digital Twin

Create a **condition-based model** that includes all relevant information from the design stage up to inspection data

Traditional
beam
model
using SCF

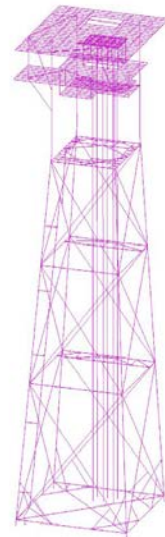

New approach



Dynamic, holistic
3-D calculated
Digital Twin

TRUE REPRESENTATION IN REAL TIME (2/4)

2. Install sensors on asset, link to Digital Twin

Installation of sensors (accelerometers, strain gauges, etc..) and connections for the platform

Sensors provide continuous data stream for **real-time monitoring**

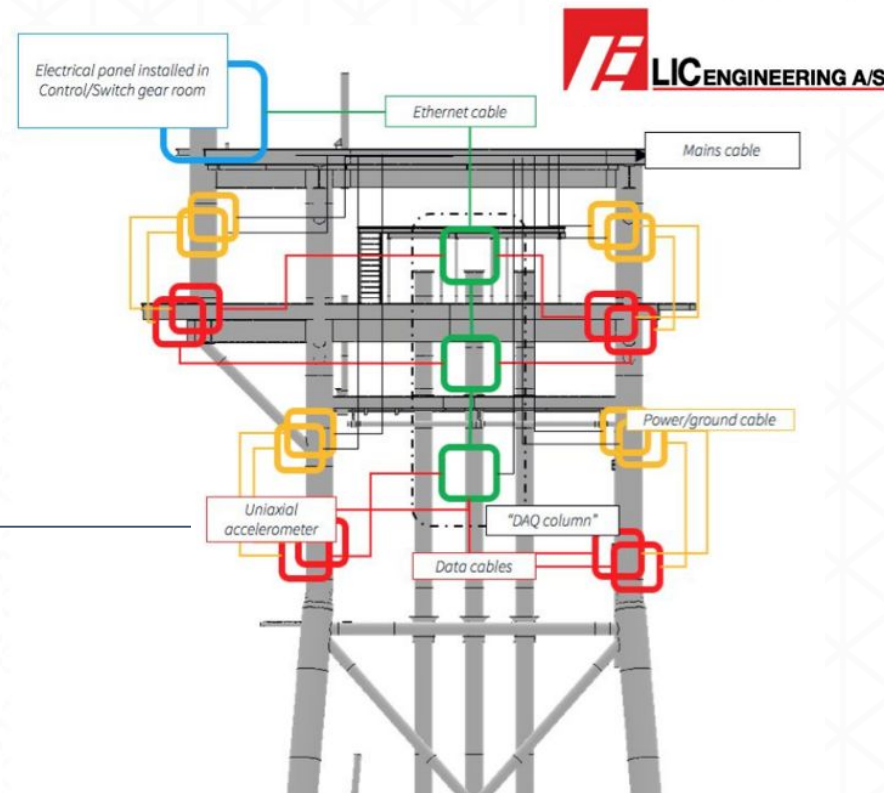

Sensor data is linked to the Digital Twin

TRUE REPRESENTATION IN REAL TIME (3/4)

3. Calibrate Digital Twin based on data flows

1

DATA COLLECTION

Initial data collection of
reference data

2

DIGITAL TWIN CALIBRATION

Tuning/updates based on
new inputs

3

DIGITAL TWIN EVALUATION

New state of the asset
assessed

CONDITION BASED PREDICTIVE DIGITAL TWIN

4. Integration with sensor data

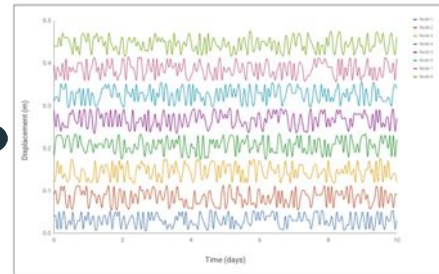
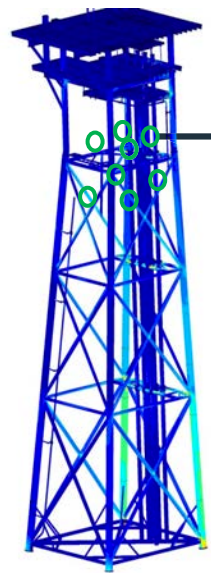

Sensor data (displacements)



Day 1



Day 4



Day 10

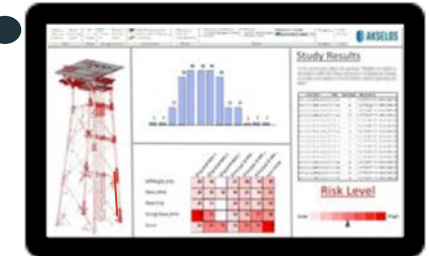

The calibrated displacements and stresses enable measurement-based analysis of the entire structure (e.g. fatigue and buckling code checks such as ISO 19902, API, AISC, DNVGL, etc., soil/pile monitoring, failure mode analysis, anomaly detection).

AKSELOS AND VALUE GENERATION – FIXED PLATFORM CASE STUDY



Over 15 years of additional structural life was unlocked from the asset.



Lower OPEX than anticipated. Better Economic outcome.



Reduced one time engineering costs.

**Case Study:
Life Extension of Hydro Plant
- Pump storage unit**

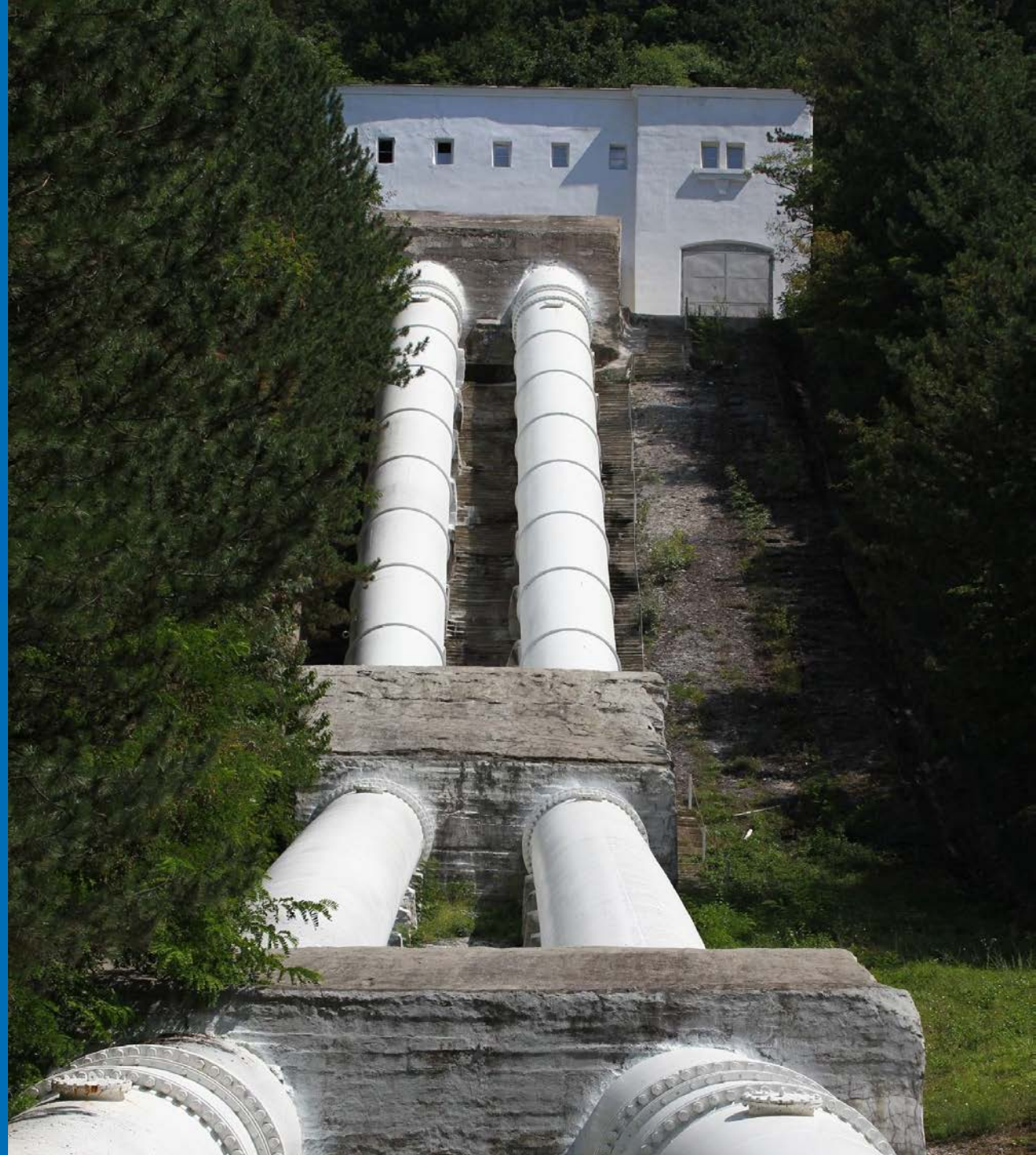

Life Extension of Hydro Plant – Pump storage unit

BUSINESS CHALLENGE

- Ageing assets approaching end of design life
- Unqualified structural risks plus high Inspection costs
- Decommissioning

BENEFITS

- Extend Electrical Generation capacity & increase revenue

AVOID OR POSTPONE A MAJOR CAPEX PROJECT

SCOPE

- Hydro Pump Station Asset
- Identify a new minimum operational life
 - Identify best fit analog data for digital model

OPPORTUNITY

- Life Extension of existing Pressure manifold with improved structural modelling and assessment
- Lower Inspection Cost
- Upside: Assess future modes of operation



EXPECTED VALUE

>> 5 X ROI

1. **Digital Twin Context**
2. **Technology Overview**
3. **Examples and Case Studies**
4. **Mathematical Background**



Partial Differential Equations

- used to model physical systems (e.g. structures, fluids, thermal, acoustics, electromagnetics, ...)
- depend on model parameters (e.g. material properties, model geometry, loads, boundary conditions, ...)

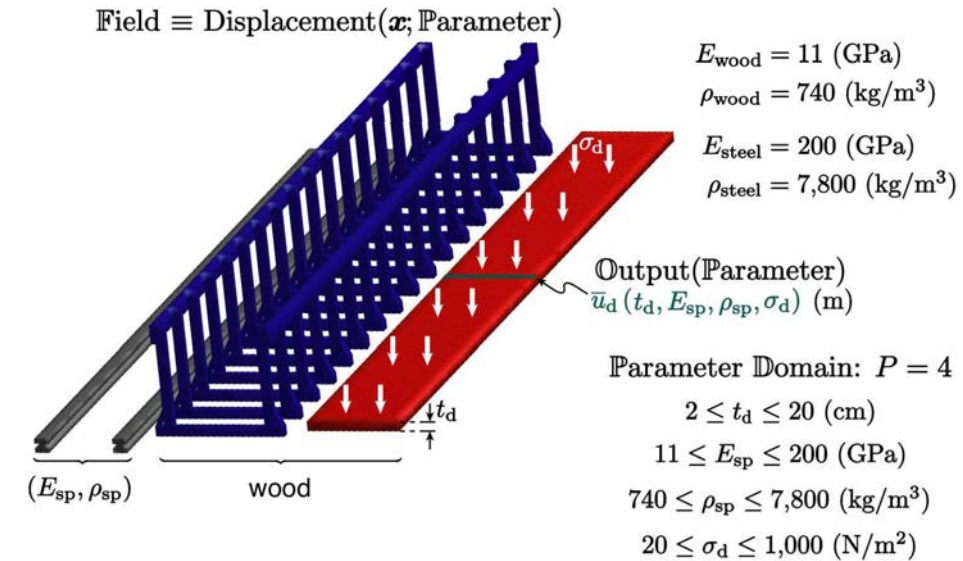
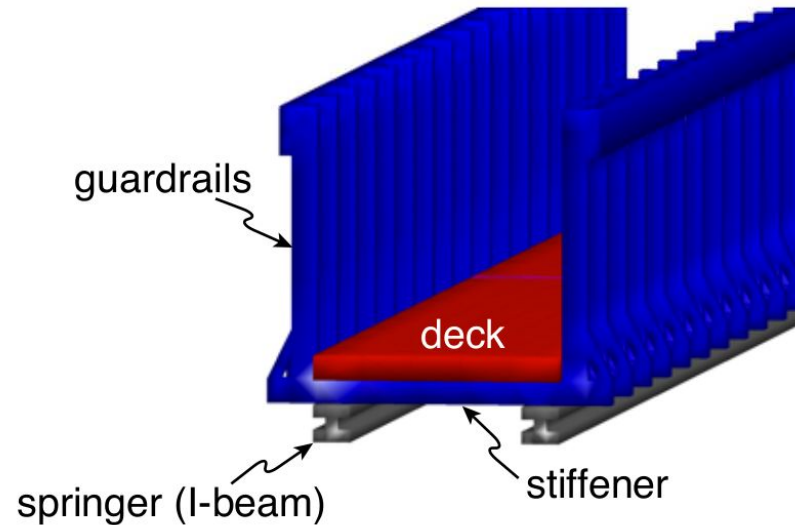

PDE:
$$\begin{cases} -\nabla \cdot \sigma = f, & \text{on } \Omega, \\ \sigma \cdot n = t, & \text{on } \partial\Omega_t, \\ u = u_d, & \text{on } \partial\Omega_d. \end{cases}$$

Many Query Context

Task:

- Solve the PDE many times with different parameter values
- Required in, e.g., optimization and uncertainty quantification

Typical approach with FEA:

- For each new parameter value, solve PDE from scratch
- For a large mesh and associated many degrees of freedom, the response time is slow and it hence becomes **computationally infeasible** if solutions for many different parameters are required

Goal:

- Develop reduced order models which allow for fast online evaluation time while maintaining accuracy

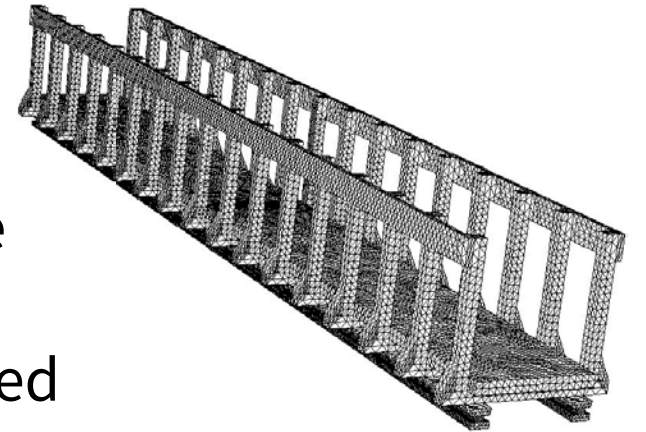

Reduced Order Models

Reduced order modeling is a family of numerical methods for reducing the computational cost associated with evaluating high-fidelity models such as FEA, CFD, finite differences

Very active research topic in academia for at least 2 decades, with a range of different methods, e.g.:

- Proper Orthogonal Decomposition (POD)
- Reduced Basis (RB) methods
- Low-rank tensor methods
- Gaussian Process Regression
- ...

Yields surrogate models that are well-suited in **real-time** or **many query** contexts

The Reduced Basis Method

- Offline/Online decomposition to separate model training from fast model evaluation
- Model training by FEA solves at greedily chosen parameter samples (offline)
- Very fast evaluation in online stage

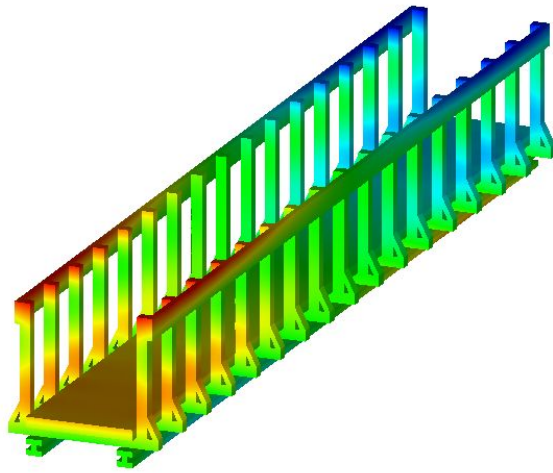

$n = 1$

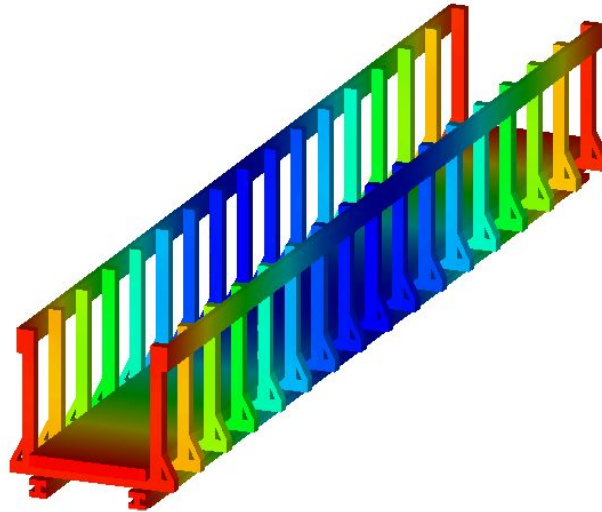

$n = 2$

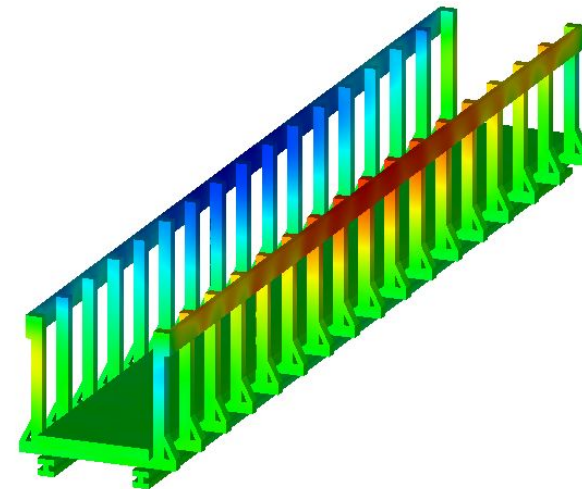

$n = 3$

Accuracy with $n = 28$ samples: $\epsilon = 10^{-4}$ in this case

The Reduced Basis Method

- RB method automatically constructs an approximation space that is highly targeted for solving the PDE
- In contrast, the full FEA approximation space is completely untargeted, e.g. it can represent arbitrary data **irrelevant to solving the PDE**, such as “random noise”:

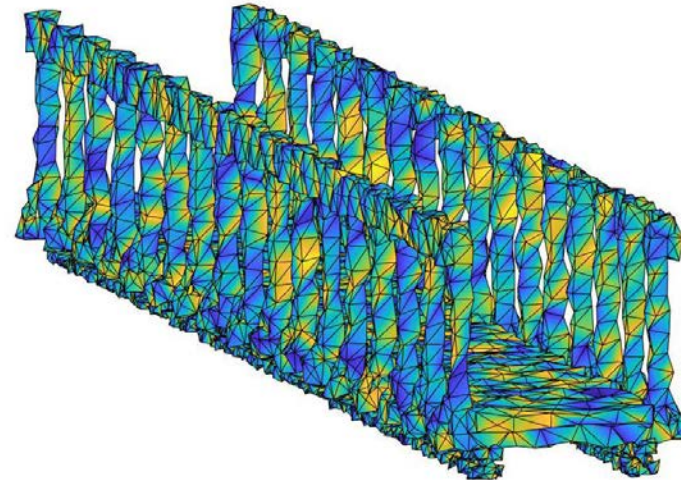
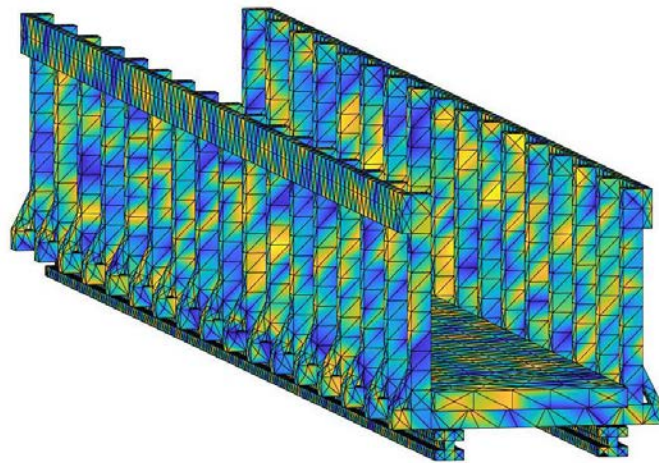

Extension to Components

Construct RB models for components, and connect components together to form large parametrized models:

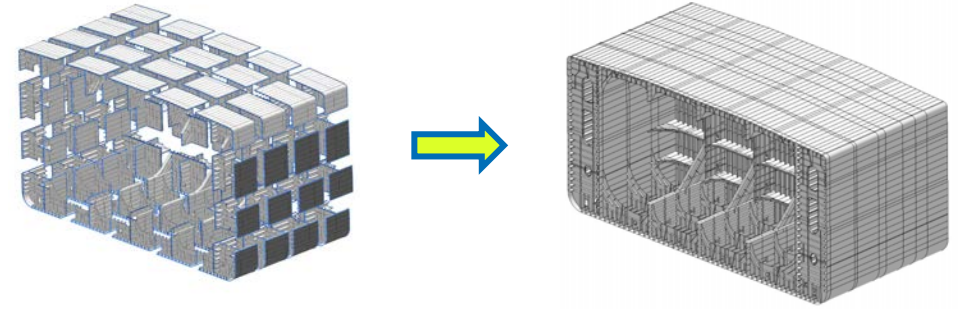

- **Large models:** Component training involves individual components or small groups of components only, hence never need to solve full model with FEA during Offline stage
- **Many parameters:** RB method requires relatively few parameters, but each component may possess a different (small) set of parameters
- **Topology changes:** Simply add/remove/replace components and re-solve

Retain the speed of RB: Typically observe **1000x speedup** or more compared to FEA for large-scale models

Incorporating Nonlinear Analysis

RB method applies to linear problems, but many engineering problems involve nonlinearities:

Core idea: Split domain into “linear” and “nonlinear” regions

Key points:

- Arbitrary nonlinearities in FEA region (e.g. contact, plasticity, finite strain)
- Accelerate the linear region, fast for “localized nonlinearities”
- Formulation is fully conforming, numerically robust

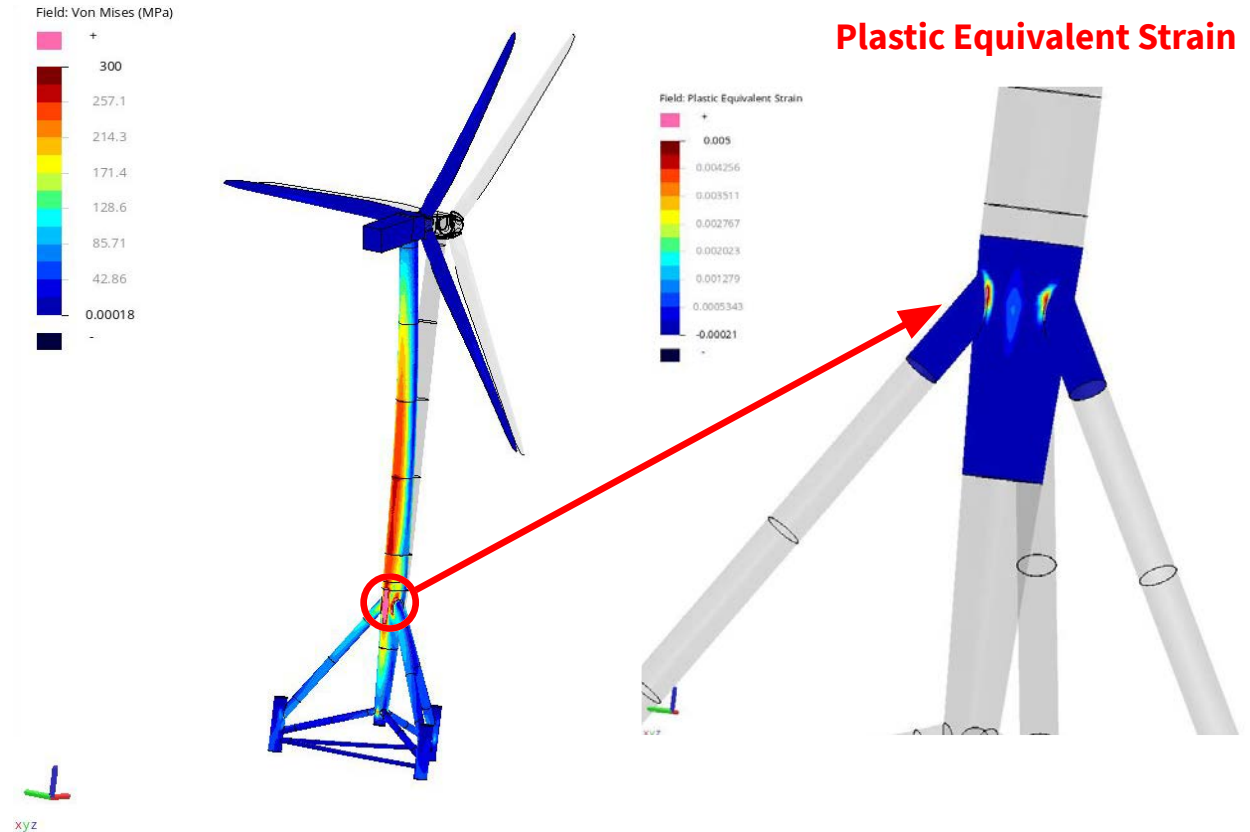

A revolution in how we build, manage, and protect our critical infrastructure



SAFETY

Manage **structural safety** risk for your **entire asset**.

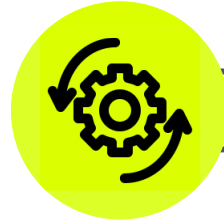

EFFICIENCY

Reduce **unplanned downtime, OPEX**.



ASSET INTEGRITY

Lead operators towards **optimal asset integrity**.

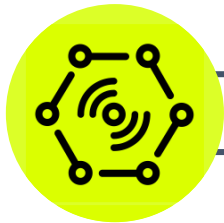

DIGITAL ENABLER

Interact with your entire asset.

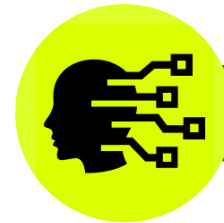

DIGITAL TRANSFORMATION

Create intelligent, **machine DNA**.